

***msi***<sup>®</sup>

**G4101**

**MS-S337**

Server System  
User Guide

# Contents

Regulatory Notices .....	4
Safety Information .....	6
System Specifications .....	7
System Overview .....	8
System Block Diagram .....	10
System Storage Topology .....	11
NVMe Signal .....	11
System LED Indicators.....	12
Motherboard Overview.....	13
Motherboard Storage.....	14
Motherboard Expansion Slots .....	16
Motherboard Connectors .....	17
Power Connectors .....	17
Cooling Connectors .....	19
USB Connectors .....	21
Other Connectors .....	23
Motherboard Jumpers.....	32
Onboard LEDs.....	33
BMC_HB_LED: BMC Heartbeat LED.....	33
SEG_LED1~4: Port 80 Debug LEDs.....	34
Getting Started.....	35
Necessary Tools .....	35
Safety Precautions.....	35
System Setup .....	36

## Revision

V1.0, 2024/03

Drive Bay .....	36
Installing 2.5" HDD/ SSD .....	36
System Cover .....	37
Removing System Cover .....	37
CPU & Cooler .....	38
Removing Preinstalled Liquid Cooling Module .....	39
Installing CPU .....	40
Installing Heatsink .....	43
Installing Liquid Cooling Module .....	44
Memory .....	47
Recommended Memory Population .....	48
Installing Memory Modules .....	49
M.2 M Key .....	50
Installing an M.2 SSD .....	50
GPGPU Card .....	51
Installing GPGPU Card .....	51
Cable Routing .....	54
Power Cables .....	54
I2C Cables .....	55
Cables for Front & Rear I/O .....	56
Storage Cables .....	57
Slide Rail .....	58
Disassembling Slide Rail .....	58
Installing Inner Rail onto the Chassis .....	59
Retracting Outer Rail Bracket .....	60
Attaching Outer Rail Bracket to Rack Frame .....	61
Installing Chassis into Rack .....	62
Removing Chassis from Rack .....	63
Detaching Outer Rail Bracket from Rack Frame .....	64
Detaching Inner Rail from the Chassis .....	65

# Regulatory Notices

## WEEE Statement

Under the European Union (“EU”) Directive on Waste Electrical and Electronic Equipment, Directive 2012/19/EU, products of “electrical and electronic equipment” cannot be discarded as municipal waste anymore and manufacturers of covered electronic equipment will be obligated to take back such products at the end of their useful life.



## Chemical Substances Information

In compliance with chemical substances regulations, such as the EU REACH Regulation (Regulation EC No. 1907/2006 of the European Parliament and the Council), MSI provides the information of chemical substances in products at:

<https://csr.msi.com/global/index>

## CE Conformity

Hereby, Micro-Star International CO., LTD declares that this device is in compliance with the essential safety requirements and other relevant provisions set out in the European Directive.



## FCC-A Radio Frequency Interference Statement

This equipment has been tested and found to comply with the limits for a Class A digital device, pursuant to Part 15 of the FCC Rules. These limits are designed to provide reasonable protection against harmful interference when the equipment is operated in a commercial environment. This equipment generates, uses and can radiate radio frequency energy and, if not installed and used in accordance with the instruction manual, may cause harmful interference to radio communications. Operation of this equipment in a residential area is likely to cause harmful interference, in which case the user will be required to correct the interference at his own expense.



### Notice 1

The changes or modifications not expressly approved by the party responsible for compliance could void the user’s authority to operate the equipment.

### Notice 2

Shielded interface cables and AC power cord, if any, must be used in order to comply with the emission limits.

This device complies with Part 15 of the FCC Rules. Operation is subject to the following two conditions:

- This device may not cause harmful interference, and
- This device must accept any interference received, including interference that may cause undesired operation.



## Battery Information

Please take special precautions if this product comes with a battery.

- Danger of explosion if battery is incorrectly replaced. Replace only with the same or equivalent type recommended by the manufacturer.
- Avoid disposal of a battery into fire or a hot oven, or mechanically crushing or cutting of a battery, which can result in an explosion.
- Avoid leaving a battery in an extremely high temperature or extremely low air pressure environment that can result in an explosion or the leakage of flammable liquid or gas.
- Do not ingest battery. If the coin/button cell battery is swallowed, it can cause severe internal burns and can lead to death. Keep new and used batteries away from children.

### European Union:



Batteries, battery packs, and accumulators should not be disposed of as unsorted household waste. Please use the public collection system to return, recycle, or treat them in compliance with the local regulations.

### BSMI:



廢電池請回收

For better environmental protection, waste batteries should be collected separately for recycling or special disposal.

### California, USA:



The button cell battery may contain perchlorate material and requires special handling when recycled or disposed of in California.

For further information please visit:

<http://www.dtsc.ca.gov/hazardouswaste/perchlorate/>

## Copyright and Trademarks Notice

**msi**

**MSI**

**微星**

**微星科技**  
MICRO-STAR INTERNATIONAL



Copyright © Micro-Star Int'l Co., Ltd. All rights reserved. The MSI logo used is a registered trademark of Micro-Star Int'l Co., Ltd. All other marks and names mentioned may be trademarks of their respective owners. No warranty as to accuracy or completeness is expressed or implied. MSI reserves the right to make changes to this document without prior notice.

## Technical Support

If a problem arises with your product and no solution can be obtained from the user's manual, please contact your place of purchase or local distributor. Alternatively, please visit <https://eps.msi.com/support> for further guidance.

# Safety Information

- Always read the safety instructions carefully.
- Keep this User's Manual for future reference.
- Keep this equipment away from humidity.
- Lay this equipment on a reliable flat surface before setting it up.
- The openings on the enclosure are for air convection hence protects the equipment from overheating. **Do not cover the openings.**
- Make sure the voltage of the power source and adjust properly before connecting the equipment to the power inlet.
- Place the power cord such a way that people can not step on it. Do not place anything over the power cord.
- Always unplug the power cord before inserting any add-on card or module.
- All cautions and warnings on the equipment should be noted.
- Never pour any liquid into the opening that could damage or cause electrical shock.
- If any of the following situations arises, get the equipment checked by service personnel:
  - The power cord or plug is damaged.
  - Liquid has penetrated into the equipment.
  - The equipment has been exposed to moisture.
  - The equipment does not work well or you can not get it work according to User's Manual.
  - The equipment has dropped and damaged.
  - The equipment has obvious sign of breakage.
- **Do not leave this equipment in an environment unconditioned, storage temperature above 60°C (140°F), it may damage the equipment.**

# System Specifications





SKUs	G4101-01
Form factor	4U
Dimensions	17.2"W (447.9mm) x 6.9"H (176mm) x 32.6"D (827.3mm)
Processor	Single AMD EPYC™ 9004 Series Processors with AMD 3D V-Cache™ Technology, TDP up to 400W
Socket	1 x AMD Socket SP5
Server Management	<ul style="list-style-type: none"> <li>• 1 x 1000Base-T dedicated server management port (Realtek® RTL8211FD-CG)</li> <li>• ASPEED AST2600 with AMI MegaRAC based firmware (supports IPMI 2.0 and DMTF Redfish® API)</li> </ul>
Graphics	1 x VGA Port (from AST2600 BMC)
Memory	<ul style="list-style-type: none"> <li>• 12 x DDR5 DIMM slots, 1DPC, RDIMM/ 3DS-RDIMM</li> <li>- Max Frequency: 4800 MT/s (1DPC)</li> <li>- Max Capacity per DIMM:               <ul style="list-style-type: none"> <li>» RDIMM: 96GB</li> <li>» 3DS-RDIMM: 512GB</li> </ul> </li> </ul>
Drive Bays	12 x 2.5" U.2 PCIe 4.0 NVMe hot-swap drive bays
Internal Storage	<ul style="list-style-type: none"> <li>• 2 x M.2 M-Key slots (PCIe 3.0, 2280/ 22110)</li> <li>- M2_1: PCIe 3.0 x4</li> <li>- M2_2: PCIe 3.0 x2</li> </ul>
Expansion Slots	<ul style="list-style-type: none"> <li>• 6 x PCIe 5.0/4.0 x16 Full-height/Full-length (FHFL) slots</li> <li>- PCIe_SLOT1~4: PCIe 5.0 x16 slots (supports quad-width riser card, signal from CPU)</li> <li>- PCIe_SLOT5~6: PCIe 4.0 x16 slots (PCIe 4.0 x8 signal from CPU)</li> </ul>
USB	4 x USB 3.2 Gen 1 Type-A ports (1 x front, 2 x rear, 1 x internal)
Front Panel	<ul style="list-style-type: none"> <li>• 1 x USB 3.2 Gen 1 Type-A port</li> <li>• 1 x Power button/ LED</li> <li>• 1 x UID button/ LED</li> <li>• 1 x Reset button</li> </ul>
Rear Panel	<ul style="list-style-type: none"> <li>• 1 x 1000Base-T dedicated server management port</li> <li>• 2 x USB 3.2 Gen 1 Type-A ports</li> <li>• 1 x COM RJ45 port</li> <li>• 1 x VGA port</li> <li>• 1 x UID button</li> <li>• 3 x Status LEDs (Power/ HDD/ Fault)</li> </ul>
TPM	1 x TPM header (with SPI interface)
Security	TPM 2.0
Cooling	<ul style="list-style-type: none"> <li>• 1 x Liquid cooling module (for max 500W CPU)</li> <li>• 5 x 8038 Easy-swap chassis fans</li> </ul>
Environment	<ul style="list-style-type: none"> <li>• Operating Temperature: 0°C ~ 35°C</li> <li>• Non-operating Temperature: -20°C ~ 70°C</li> <li>• Non-operating Relative Humidity: 5% ~ 85% (non-condensing)</li> </ul>
Power Supply	(1+1) 3000W Redundant PSU 80+ Platinum
Certification	CE, FCC (Class A)

# System Overview

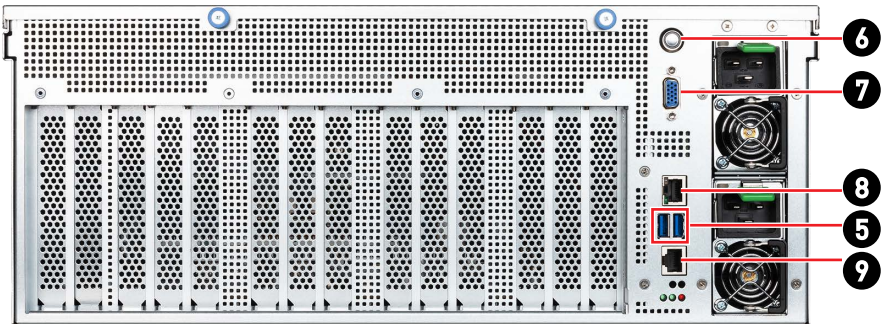

12 x 2.5" U.2 NVMe 4.0  
Hybrid Hot-Swap Drive Bays

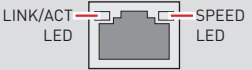
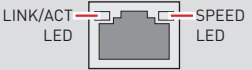
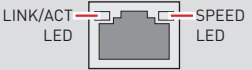

<p><b>1</b></p>	<p>  M.2 Activity LED   System Status LED   MLAN LEDs         </p>																		
<p><b>2</b></p>	<p>  System Power Button/ LED         </p>																		
<p><b>3</b></p>	<p> <b>UID LED Button</b>            (or BMC Reset Button, configured using jumper: <b>JUID_SEL1</b>)         </p>																		
<p><b>4</b></p>	<p><b>System Reset Button</b></p>																		
<p><b>5</b></p>	<p> <b>USB 3.2 Gen 1 Type-A Port</b>            This connector is provided for USB peripheral devices. (Speed up to 5 Gbps)         </p>																		
<p><b>6</b></p>	<p><b>UID Button</b></p>																		
<p><b>7</b></p>	<p><b>VGA Port</b></p>																		
<p><b>8</b></p>	<p> <b>1000Base-T dedicated server management port</b>            The standard RJ45 LAN jack is provided for connection to the Local Area Network (LAN). You can connect a network cable to it.         </p> <table border="1" data-bbox="200 853 931 1082"> <tr> <td data-bbox="200 853 473 1082" rowspan="6">  </td> <td data-bbox="473 853 611 885"><b>LED</b></td> <td data-bbox="611 853 739 885"><b>Status</b></td> <td data-bbox="739 853 931 885"><b>Description</b></td> </tr> <tr> <td data-bbox="473 885 611 986" rowspan="3">Link/ Activity LED</td> <td data-bbox="611 885 739 917">○ Off</td> <td data-bbox="739 885 931 917">No link</td> </tr> <tr> <td data-bbox="611 917 739 949">● Green</td> <td data-bbox="739 917 931 949">Linked</td> </tr> <tr> <td data-bbox="611 949 739 986">● Blinking</td> <td data-bbox="739 949 931 986">Data activity</td> </tr> <tr> <td data-bbox="473 986 611 1082" rowspan="3">Speed LED</td> <td data-bbox="611 986 739 1018">○ Off</td> <td data-bbox="739 986 931 1018">10 Mbps</td> </tr> <tr> <td data-bbox="611 1018 739 1050">● Orange</td> <td data-bbox="739 1018 931 1050">100 Mbps</td> </tr> <tr> <td data-bbox="611 1050 739 1082">● Green</td> <td data-bbox="739 1050 931 1082">1 Gbps</td> </tr> </table>		<b>LED</b>	<b>Status</b>	<b>Description</b>	Link/ Activity LED	○ Off	No link	● Green	Linked	● Blinking	Data activity	Speed LED	○ Off	10 Mbps	● Orange	100 Mbps	● Green	1 Gbps
	<b>LED</b>		<b>Status</b>	<b>Description</b>															
	Link/ Activity LED		○ Off	No link															
			● Green	Linked															
			● Blinking	Data activity															
	Speed LED		○ Off	10 Mbps															
		● Orange	100 Mbps																
● Green		1 Gbps																	
<p><b>9</b></p>	<p><b>COM RJ45 Port</b></p>																		



# System Storage Topology



## NVMe Signal

NVMe #11	NVMe #9	NVMe #7	NVMe #5	NVMe #3	NVMe #1
NVMe #12	NVMe #10	NVMe #8	NVMe #6	NVMe #4	NVMe #2

12 x 2.5" NVMe					
NVMe #11	NVMe #9	NVMe #7	NVMe #5	NVMe #3	NVMe #1
CPU0 P3	CPU0 P3	CPU0 P2	CPU0 P2	CPU0 P1	CPU0 P1
Lanes 8:11	Lanes 0:3	Lanes 8:11	Lanes 0:3	Lanes 8:11	Lanes 0:3
NVMe #12	NVMe #10	NVMe #8	NVMe #6	NVMe #4	NVMe #2
CPU0 P3	CPU0 P3	CPU0 P2	CPU0 P2	CPU0 P1	CPU0 P1
Lanes 12:15	Lanes 4:7	Lanes 12:15	Lanes 4:7	Lanes 12:15	Lanes 4:7

# System LED Indicators

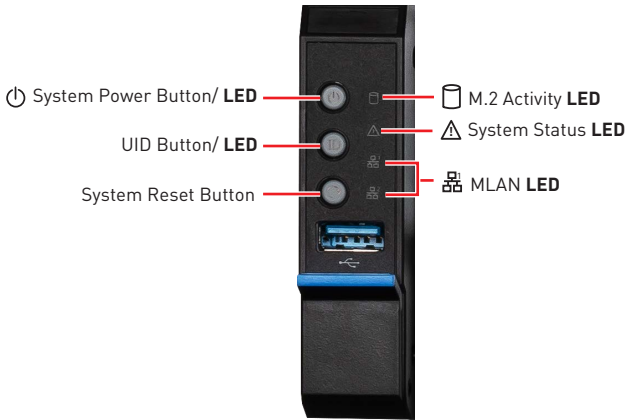

LED	LED State	Description
Power LED	● Blue	System is on
	◐ Blinking	System is sleeping
	○ Off	System is off System is on ACPI S4, S5 state
UID LED	● Blue	Identify active via command or button
	○ Off	No identification
⚠ System Status LED	● Green	BMC initialization
	● Red	System has failed
	○ Off	System is running/ normal operation
🌐 MLAN LED	● Green	LAN link is established
	◐ Blinking	LAN activity is occurring
	○ Off	LAN link is not established
🗄 M.2 Activity LED	● Amber	Storage drive in use
	○ Off	No storage drive activity



# Motherboard Overview

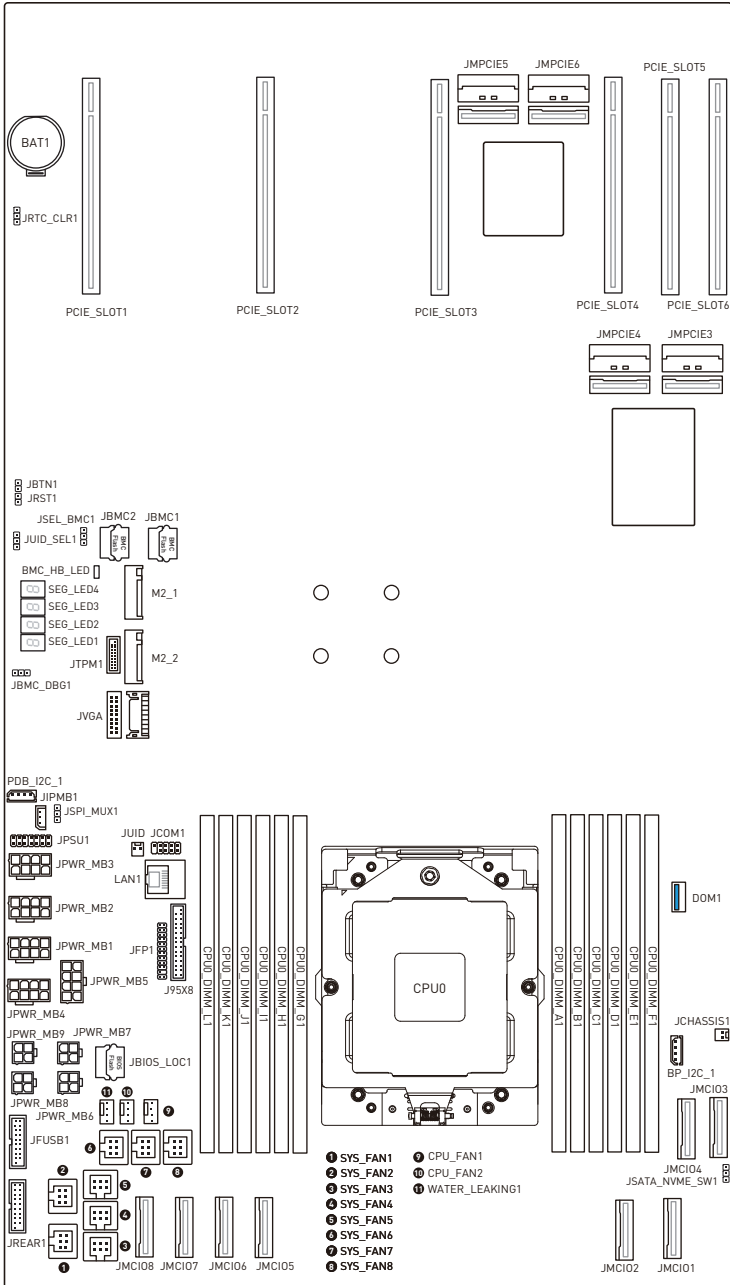

# Motherboard Storage

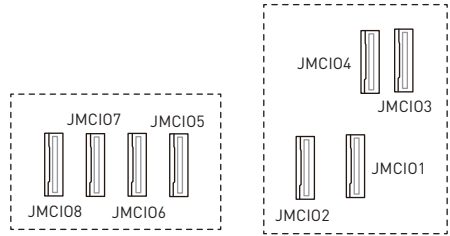
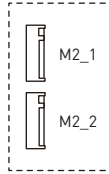
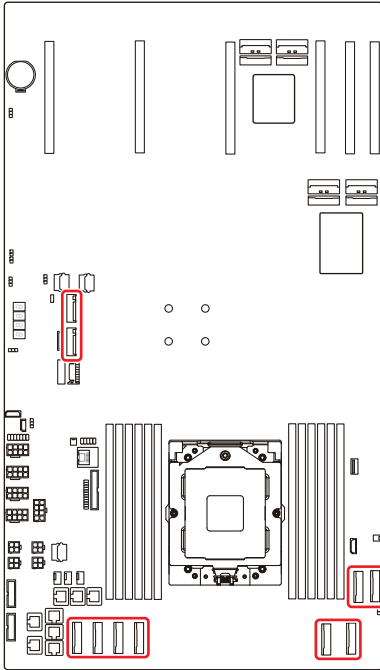

Name	Description
JMCI01~2	PCIe 5.0 x8 32 GT/s (Default)
	SATA 3.0 6 Gb/s
JMCI03~8	PCIe 5.0 x8 32 GT/s
M2_1	PCIe 3.0 x4 8 GT/s
M2_2	PCIe 3.0 x2 8 GT/s

## M2\_1~2: M.2 Slots (M Key, PCIe 3.0, 22110/ 2280)

The M.2 slot supports solid-state drive (SSD). For installation procedure, please refer to “**System Setup > M.2 M Key**”.

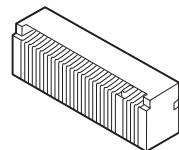

## JMCI01~8: MCI0 8i Connectors

These connectors serve as MCI0 interface ports, supporting both SATA and NVMe devices.

	A1	GND	B1	GND
	A2	SSD_RX+	B2	SSD_TX+
	A3	SSD_RX-	B3	SSD_TX-
	A4	GND	B4	GND
	A5	SSD_RX+	B5	SSD_TX+
	A6	SSD_RX-	B6	SSD_TX-
	A7	GND	B7	GND
	A8	NC	B8	SMB_PEHPCPU_LV3_SCL
	A9	FM_SMB_CPU_ALERT_N	B9	SMB_PEHPCPU_LV3_SDA
	A10	GND	B10	GND
	A11	CLK_100M_SSD_DP	B11	RST_PCIE_CPU_PERST_N
	A12	CLK_100M_SSD_DN	B12	FM_PCIE_SSD_PRSNNT_N
	A13	GND	B13	GND
	A14	SSD_RX+	B14	SSD_TX+
	A15	SSD_RX-	B15	SSD_TX-
	A16	GND	B16	GND
	A17	SSD_RX+	B17	SSD_TX+
	A18	SSD_RX-	B18	SSD_TX-
	A19	GND	B19	GND
	A20	SSD_RX+	B20	SSD_TX+
	A21	SSD_RX-	B21	SSD_TX-
	A22	GND	B22	GND
	A23	SSD_RX+	B23	SSD_TX+
	A24	SSD_RX-	B24	SSD_TX-
	A25	GND	B25	GND
	A26	NC	B26	SMB_PEHPCPU_LV3_SCL
	A27	FM_SMB_CPU_ALERT_N	B27	SMB_PEHPCPU_LV3_SDA
	A28	GND	B28	GND
	A29	CLK_100M_SSD_DP	B29	RST_PCIE_CPU_PESSET_N
	A30	CLK_100M_SSD_DN	B30	FM_PCIE_SSD_PRSNNT_N
	A31	GND	B31	GND
	A32	SSD_RX+	B32	SSD_TX+
	A33	SSD_RX-	B33	SSD_TX-
	A34	GND	B34	GND
	A35	SSD_RX+	B35	SSD_TX+
	A36	SSD_RX-	B36	SSD_TX-
	A37	GND	B37	GND

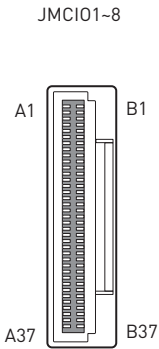

# Motherboard Expansion Slots

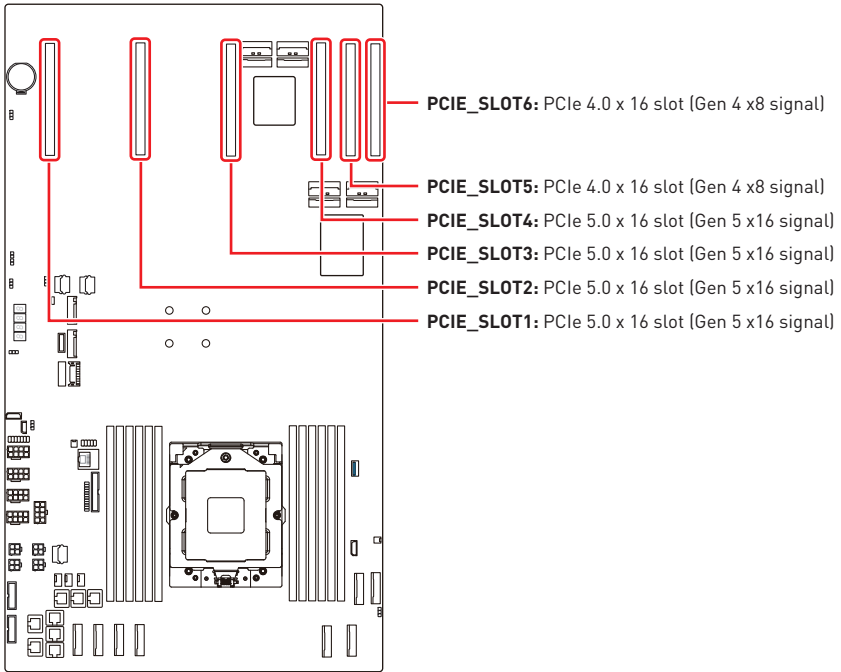

## PCIE\_SLOT1~6: PCIe Expansion Slots

The PCI Express(Peripheral Component Interconnect Express) slots support PCIe interface expansion cards.

### **Important**

*When adding or removing expansion cards, make sure that you unplug the power supply first. Meanwhile, read the documentation for the expansion card to configure any necessary hardware or software settings for the expansion card, such as jumpers, switches or BIOS configuration.*

# Motherboard Connectors

## Power Connectors

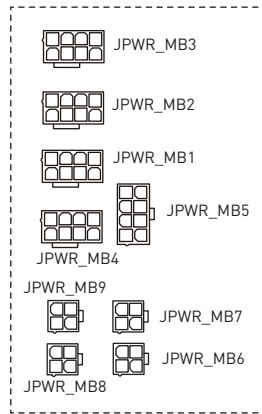
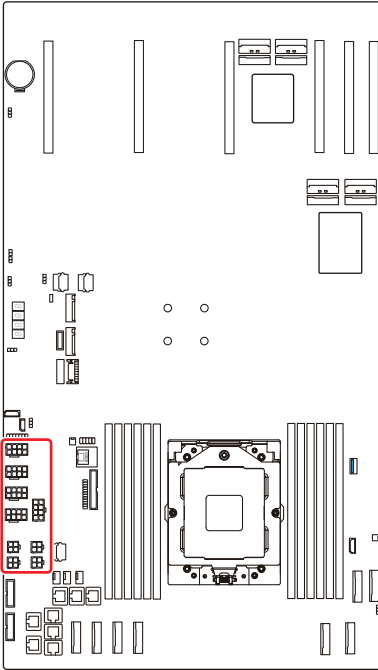

### JPWR\_MB1~4: 12V Power Connectors (for MB PWR)

JPWR_MB1~4		1	GND	5	P12V
		2	GND	6	P12V
		3	GND	7	P12V
		4	GND	8	P12V

### JPWR\_MB5: 12V Power Connector (for BP PWR)

JPWR_MB5		1	GND	5	P12V
		2	GND	6	P12V_AUX
		3	GND	7	P12V_AUX
		4	GND	8	P12V_STBY

## JPWR\_MB6, JPWR\_MB8: Power Connectors (5V)

JPWR_MB6 JPWR_MB8		1	GND	3	P5V
		2	GND	4	P5V

## JPWR\_MB7, JPWR\_MB9: Power Connectors (3V)

JPWR_MB7 JPWR_MB9		1	GND	3	P3V
		2	GND	4	P3V

## JPWR\_HDD1: HDD/SATA Power Connector (on PDB)

JPWR_HDD1		1	GND	5	P12V
		2	GND	6	P12V
		3	GND	7	P12V
		4	GND	8	P12V

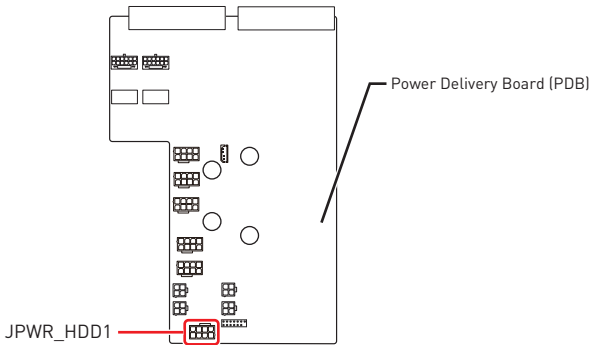

### Important

Make sure that all power connectors are securely connected to the power supply to ensure stable operation of the motherboard.

## Cooling Connectors

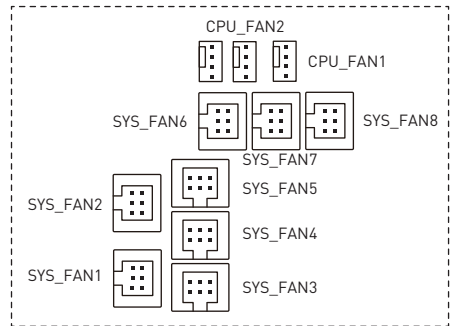
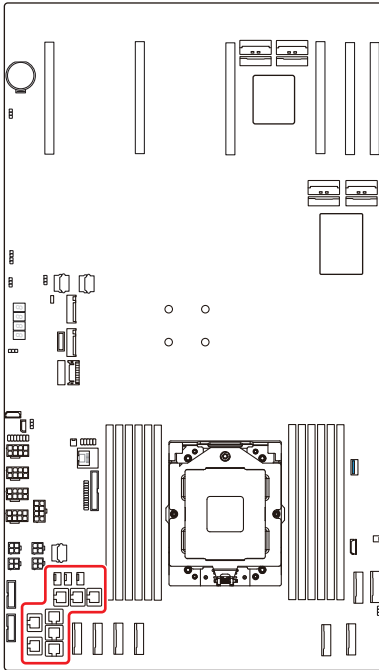

### SYS\_FAN1~8: System/CPU Fan Connectors

The fan power connectors support system/ CPU cooling fans.

SYS_FAN1~8		1	FAN_TACH	2	P12V
		3	PWM	4	P12V
		5	GND	6	GND

### CPU\_FAN1~2: CPU Pump Connectors

The fan power connectors support CPU pump.

CPU_FAN1~2		1	GND	3	FAN_TACH
		2	P12V	4	FAN_PWM

## WATER\_LEAKING1: CPU Pump Water Leak Detection Connector

This connector is for detecting water leaks in the CPU water cooling pump. If a leak is detected, the system will automatically shut down for protection.

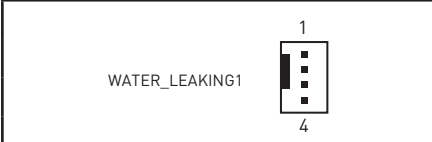
	1	P5V_AUX
	2	Water_Leaking
	3	GND
	4	GND



# USB Connectors

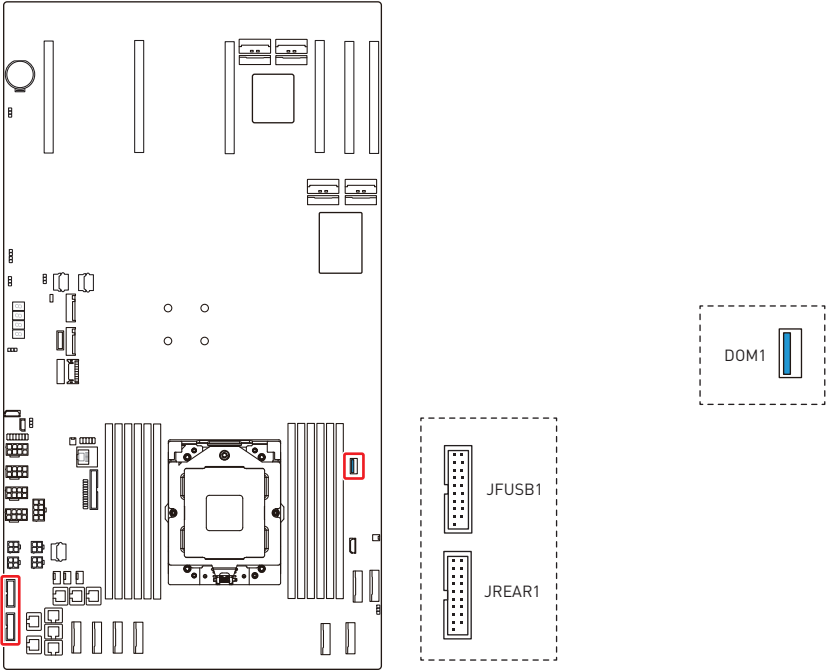

## DOM1: USB 3.2 Gen 1 Type-A Port

The USB (Universal Serial Bus) port is used for connecting USB devices such as keyboards, mice, or other compatible peripherals. It supports data transfer rates up to **5 Gbps** and is backward-compatible with USB 2.0 devices.

DOM1



## JREAR1, JFUSB1: USB 3.2 Gen 1 Headers

These headers are backward-compatible with USB 2.0 devices and support data transfer rate up to **5 Gbps**.

				JREAR1			
				1	P5V_AUX_USB_BP2	11	HUB_SSD2P_ESD_DP
				2	HUB_SSRX1N_ESD	12	HUB_SSD2N_ESD_DN
				3	HUB_SSRX1P_ESD	13	GND
				4	GND	14	HUB_SSTX2_C_ESD_TXP
				5	HUB_SSTX1_C_ESD_TXN	15	HUB_SSTX2_C_ESD_TXN
				6	HUB_SSTX1_C_ESD_TXP	16	GND
				7	GND	17	HUB_SSRX2P_ESD
				8	HUB_SSD1N_ESD_DN	18	HUB_SSRX2N_ESD
				9	HUB_SSD1P_ESD_DP	19	P5V_AUX_USB_BP3
				10	NC	20	No Pin
				JFUSB1			
				1	P5V_AUX_USB_BP4	11	HUB_SSD4P_ESD_DP
				2	HUB_SSRX3N_ESD_RXN	12	HUB_SSD4N_ESD_DN
				3	HUB_SSRX3P_ESD_RXP	13	GND
				4	GND	14	HUB_SSTX4_C_TXP_ESD_TXP
				5	HUB_SSTX3_C_TXN_ESD_TXN	15	HUB_SSTX4_C_TXP_ESD_TXP
				6	HUB_SSTX3_C_TXP_ESD_TXP	16	GND
				7	GND	17	HUB_SSRX4P_ESD_RXP
				8	HUB_SSD3N_ESD_DN	18	HUB_SSRX4N_ESD_RXN
				9	HUB_SSD3P_ESD_DP	19	P5V_AUX_USB_BP5
				10	NC	20	No Pin

  

JREAR1  
JFUSB1

## Other Connectors

### JVGA: Front VGA Header

The VGA connector is provided for monitors.

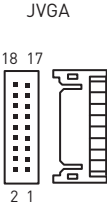
	1	NC	2	NC
	3	F_RED1	4	GND
	5	F_GRN1	6	GND
	7	F_BLU1	8	GND
	9	F_VS1	10	GND
	11	F_HS1	12	GND
	13	F_DDCDAT1	14	NC
	15	F_DDCCLK1	16	P5V
17	NC	18	NC	

### LAN1: GbE RJ45 Port (for mgmt.)

The standard RJ-45 LAN jack is for connection to the Local Area Network (LAN). You can connect a network cable to it.

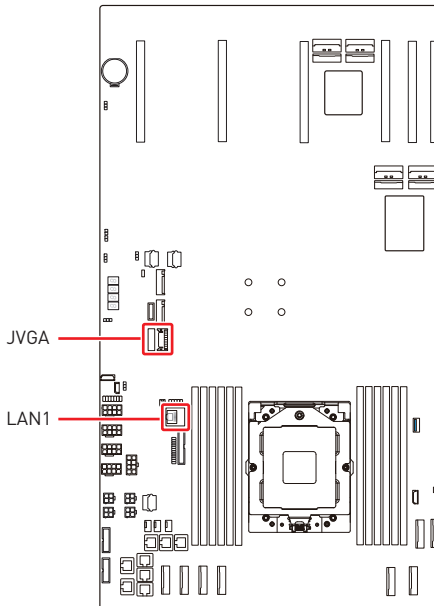

## JFP1: Front Panel Header

The front panel header is provided for electrical connection to the front panel switches and LEDs.

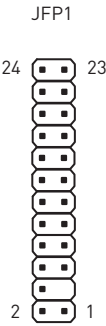
 <p>JFP1</p>	1	VDD_33_DUAL	2	P3V3_AUX
	3	N/A	4	P3V3_AUX
	5	FP_PWR_LED_B_R_N	6	FP_ID_LED_B_R_N
	7	VDD_33_RUN	8	SYS_ERR_LED#_N
	9	FP_HDD_ACT_LED_N	10	SYS_FLT_LED#_N
	11	FP_PWR_BTN_L_R	12	VDD_33_DUAL
	13	GND	14	LAN_NIC_0_ACT_N_R
	15	FP_RST_BTN_L_R	16	SMB_BMC_HSBP_STBY_LVC3_SDA
	17	GND	18	SMB_BMC_HSBP_STBY_LVC3_SCL
	19	FP_ID_BTN_N_R	20	FP_CHASSIS_INTRUSION (TP)
	21	GND	22	VDD_33_DUAL
	23	NMI_BTN_N_R	24	LAN_NIC_1_ACT_N_R

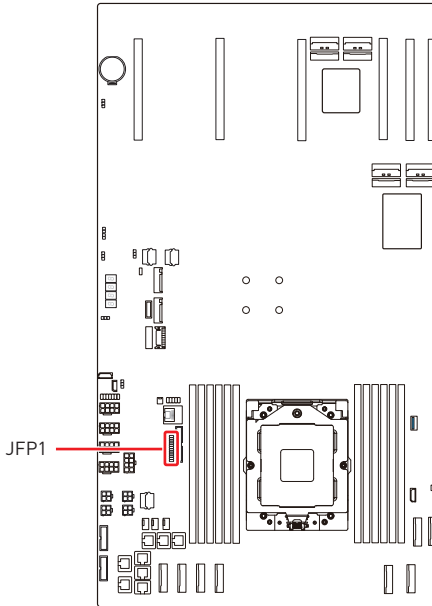

### JTPM1: SPI TPM Header

This header connects to a TPM (Trusted Platform Module) (optional). Please refer to the TPM security platform manual for more details.

	1	No pin	2	P3V3_AUX
	3	TPM_RSMRST_N	4	N/A
	5	GND	6	P3V3_AUX
	7	SPI_P0_3V3_LOC_CLK	8	P3V3_AUX
	9	P3V3_AUX	10	SPI_P0_3V3_LOC_MISO
	11	N/A	12	SPI_CPU0_3V3_MOSI
	13	SPI_TPM_CS_N	14	GND
	15	P3V3_AUX	16	N/A
	17	IRQ_TPM_SPI_N	18	P3V3_AUX
	19	P0_RESET_LS_L	20	P3V3_AUX

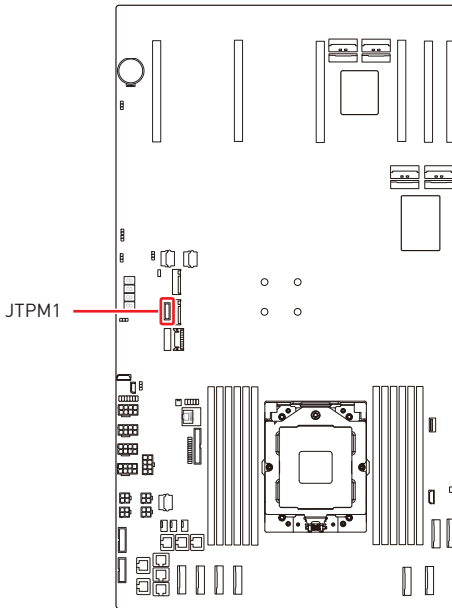

## J95X8: 95X8 I/O Board Header

The 95X8 I/O Board Header is designed to interface with the 95X8 I/O Board. This I/O Board functions as an I/O expander, enabling the expansion of input/output capabilities within a system.

	1	GPIOG7	2	PU_FAN_PCH_TACH3
	3	GPIOG6	4	PU_FAN_PCH_TACH2
	5	GND	6	GND
	7	GND	8	GND
	9	LED1_1000#	10	NC
	11	LED1_100#	12	NC
	13	LED0_AD0	14	NC
	15	CONA_DCD	16	STATUS_LED#
	17	CONA_RXD	18	HDDLED#
	19	CONA_DSR	20	CONA_TXD
	21	CONA_CTS	22	CONA_DTR
	23	CONA_RI	24	CONA_RTS
	25	NC	26	NC
	27	P5V	28	P3V3_AUX
	29	P5V	30	No pin

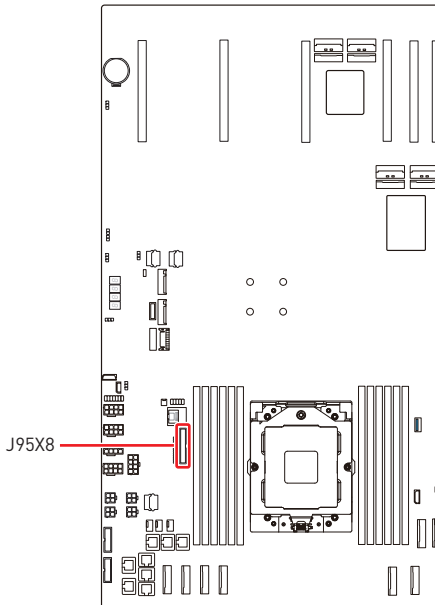

## JIPMB1: IPMB Header

Intelligent Platform Management Bus (IPMB) header is used to connect various management components, such as Baseboard Management Controller (BMC).

	1	SMB_PS1_DAT
	2	GND
	3	SMB_PS1_CLK

## JPSU1: PDB Header

This header is designed to interface with the Power Distribution Board (PDB).

	1	PMBUS_CLK1	2	VDD_33_DUAL_EN
	3	PMBUS_DATA1	4	VDD_33_DUAL_PG
	5	SMB_PMBUS_ALERT_N	6	VDD_5_DUAL_EN
	7	PS_ON_N	8	VDD_5_DUAL_PG
	9	PSU_PWR0K_SH_BUF<0>	10	VDD_33_RUN_EN
	11	PSU_PWR0K_SH_BUF<1>	12	VDD_33_RUN_PG
	13	NC	14	PSU_PWR_OK

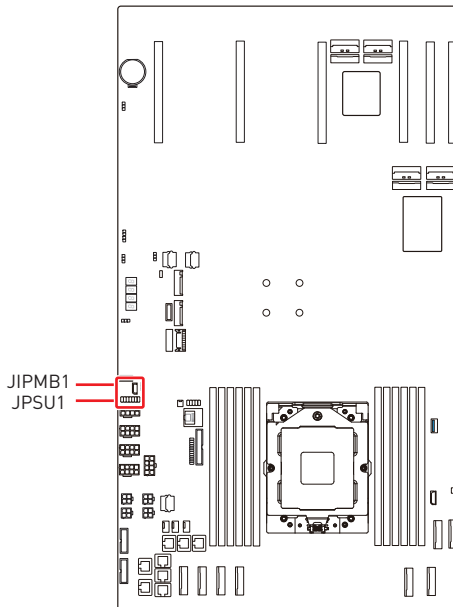

## BP\_I2C\_1, PDB\_I2C\_1: I2C Headers

I2C headers are used to connect to the System Management Bus (SMBus).

BP_I2C_1 PDB_I2C_1		1	NC
		2	BP_I2C_CLK1
		3	BP_I2C_DAT1
		4	GND

## JCOM1: COM Port Header

This header is a 16550A high speed communications port that sends/receives 16 bytes FIFOs. You can attach a serial device to it.

JCOM1  	1	CONB_DCD	2	CONB_RXD
	3	CONB_TXD	4	CONB_DTR
	5	GND	6	CONB_DSR
	7	CONB_RTS	8	CONB_CTS
	9	CONB_RI	10	No pin

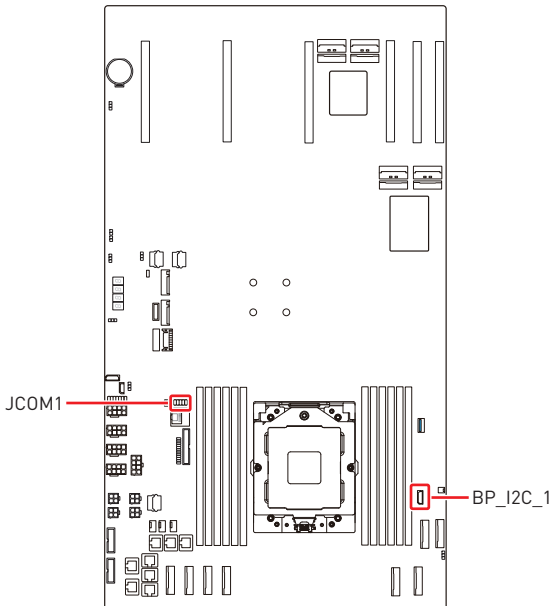



### JBTN1: Power Button Header

This header is provided to connect the system power button.

JBTN1		1	FP_PWR_BTN#	2	GND
-------	---	---	-------------	---	-----

### JRST1: Reset Button Header

This header is provided to connect the system reset button.

JRST1		1	FP_RST_BTN#	2	GND
-------	---	---	-------------	---	-----

### JUID: UID Button Header

This header is provided to connect the system UID button.

JUID		1	REAR_ID_BTN_N	2	GND
------	---	---	---------------	---	-----

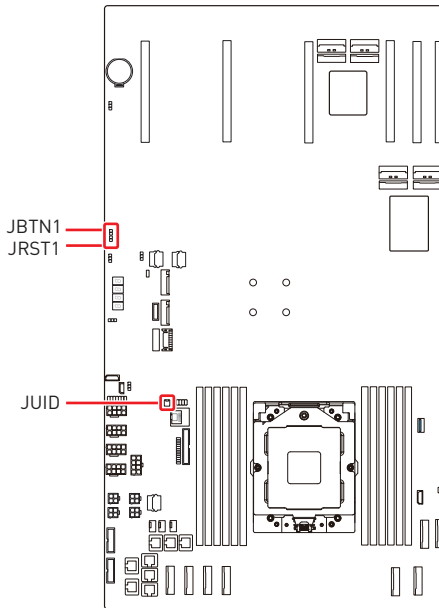

## JCHASSIS1: Chassis Intrusion Header

This header connects to the chassis intrusion switch cable. If the chassis is opened, the chassis intrusion mechanism will be activated. The system will record this status and show a warning message on the screen. To clear the warning, you must enter the BIOS utility and clear the record.

JCHASSIS1



Trigger the chassis intrusion event



Normal (default)

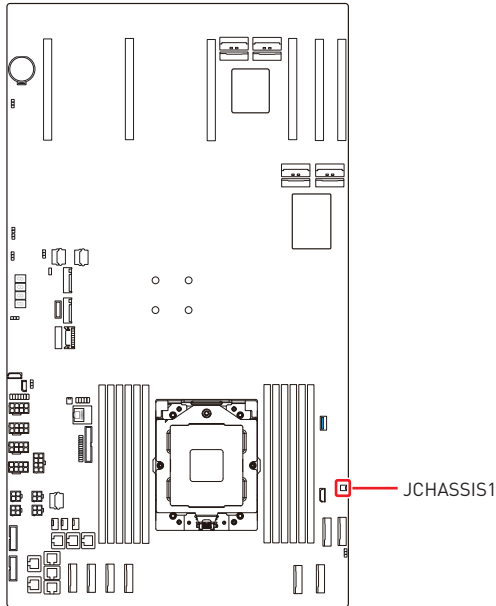

## BAT1: CMOS Battery

If the CMOS battery is out of charge, the time in the BIOS will be reset and the data of system configuration will be lost. In this case, you need to replace the CMOS battery.

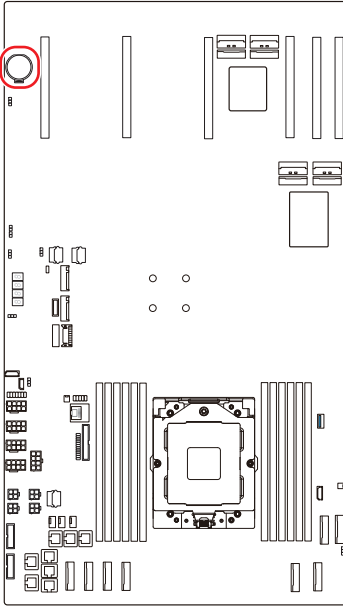

### Replacing CMOS battery

1. Push the retainer clip to free the battery.
2. Remove the battery from the socket.
3. Install the new CR2032 coin-cell battery with the + sign facing up. Ensure that the retainer holds the battery securely.

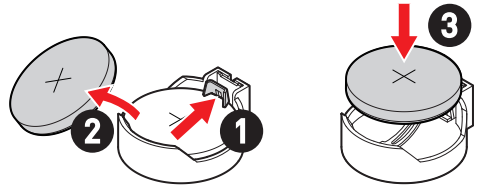

### WARNING

#### KEEP OUT OF REACH OF CHILDREN

- Swallowing can lead to chemical burns, perforation of soft tissue, can death.
- Severe burns can occur within 2 hours of ingestion.
- If you think batteries might have been swallowed or placed inside any part of the body, seek immediate medical attention.





# Motherboard Jumpers

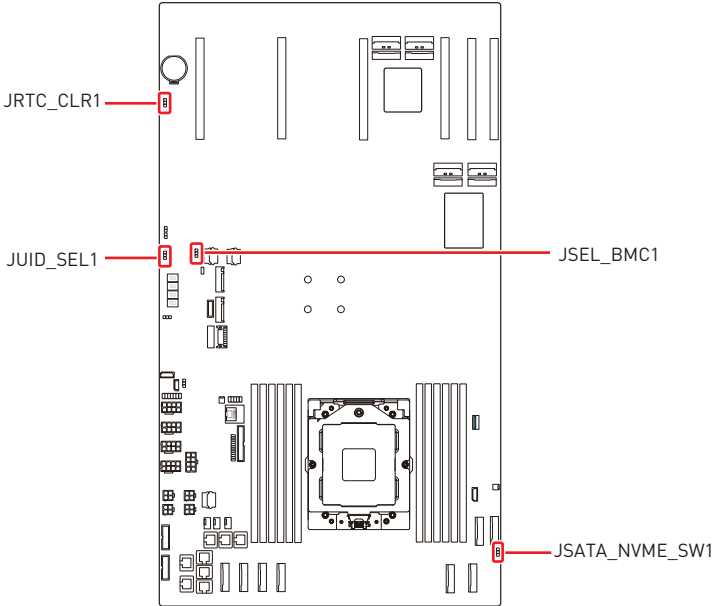

**Important**

Avoid adjusting jumpers when the system is on; it will damage the motherboard.



Jumper Name	Default Setting	Description
JRTC_CLR1	 1	1-2: Normal (Default) 2-3: Clear CMOS
JUID_SEL1	 1	1-2: UID Button (Default) 2-3: BMC RST Button
JSEL_BMC1	 1	1-2: BMC2 2-3: BMC1 (Default)
JSATA_NVME_SW1	 1	1-2: JMCIO1~2 setting to SATA SIGNAL 2-3: JMCIO1~2 setting to NVME SIGNAL (Default)

# Onboard LEDs

## BMC\_HB\_LED: BMC Heartbeat LED

This LED indicates the BMC (Baseboard Management Controller) status.

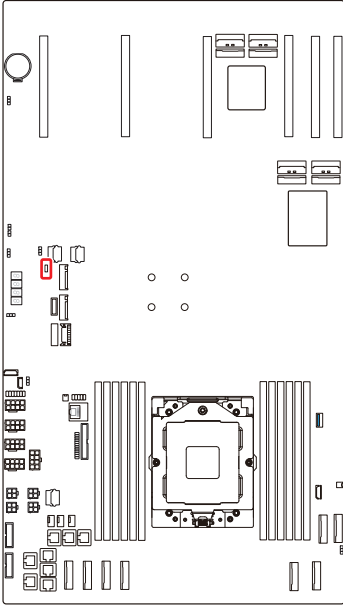

LED Status	Description
○ Off	BMC is not activated
◐ Blinking	BMC is functioning normally

## SEG\_LED1~4: Port 80 Debug LEDs

The Port 80 Debug LEDs display progress and error codes during and after POST (Power-On Self Test).

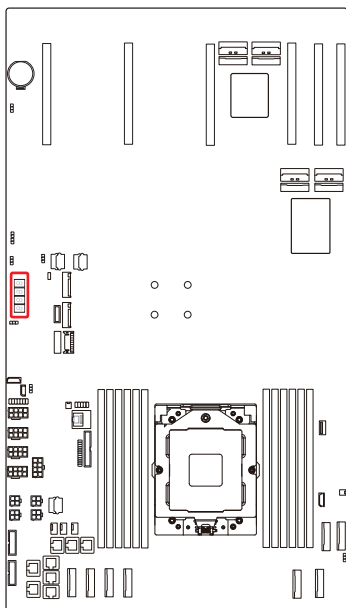

Hexadecimal Character Table

Hexadecimal	0	1	2	3	4	5	6	7
LED display	0	1	2	3	4	5	6	7
Hexadecimal	8	9	A	B	C	D	E	F
LED display	8	9	A	b	C	d	E	F

# Getting Started



## Important

- All information is subject to change without prior notice.
- The illustrations are provided for demonstrative purposes only. The appearance and internal view of your system may differ based on the model you have purchased.

## Necessary Tools



Screwdriver



Pliers



Tweezers



Anti-Static Gloves

## Safety Precautions

The following precautions should be observed while handling the system:

- Place the system on a flat and stable surface.
- Do not place the system in environments subject to mist, smoke, vibration, excessive dust, salty or greasy air, or other corrosive gases and fumes.
- Do not drop or jolt the system.
- Do not use a power adapter other than the one enclosed with the system.
- Disconnect the power cord before performing any installation procedures on the system.
- Do not perform any maintenance with wet hands.
- Prevent foreign substances, such as water, other liquids or chemicals, from entering the system while performing installation procedures.
- Use a grounded wrist strap before handling system components such as CPU, Memory, HDD, expansion cards, etc.
- Place system components on a grounded anti-static pad or on the bed that came with the components whenever the components are separated from the system.

# System Setup



**Important**

Before removing or installing any components, make sure the system is not turned on or connected to the power.

## Drive Bay

### Installing 2.5" HDD/ SSD

1. Press the tray button to release the lever.
2. Pull the HDD/ SSD assembly out of the drive bay.
3. Insert the HDD/ SSD horizontally.

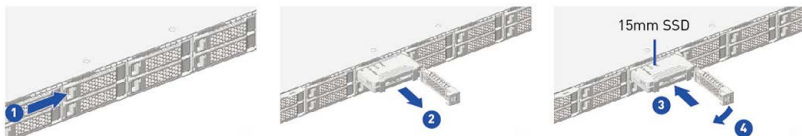

- The interposer BKT act as dummy HDD/ SSD when no drive inside.
- The interposer BKT act as spacer to support 7mm HDD/ SSD.



# System Cover

## Removing System Cover

1. Remove the **screws** securing the system on both sides.
2. Slide the covers to the front and back side of the system to remove it.

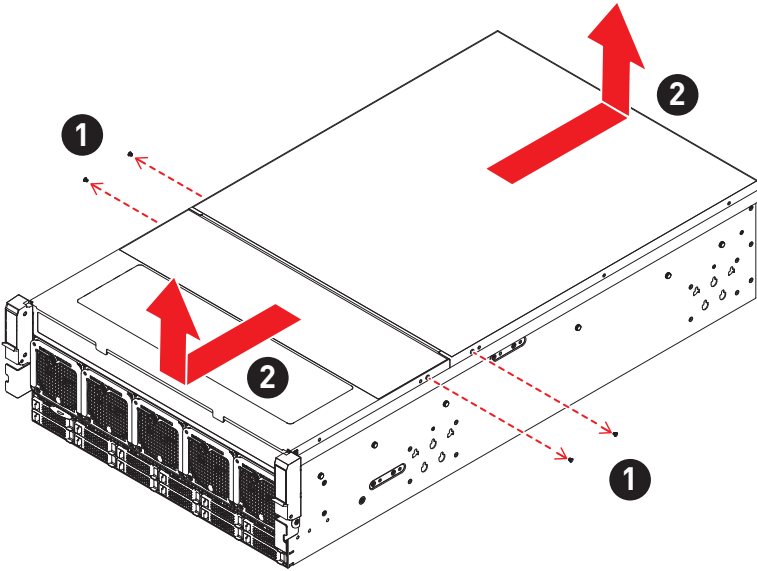

# CPU & Cooler

Use appropriate ground straps, gloves and ESD mats to protect yourself from electrostatic discharge (ESD) while installing the processor.

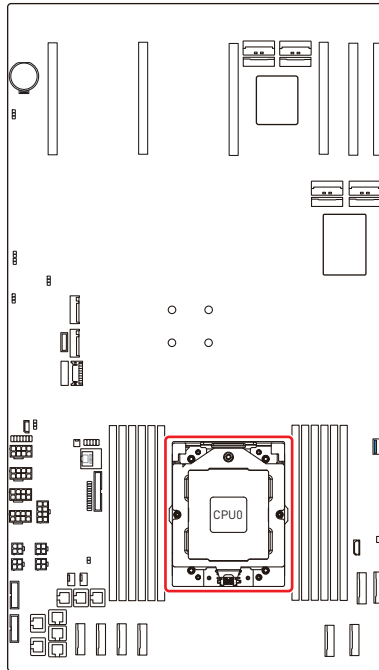

## Important

- Images are for illustration purposes only; actual parts may vary.
- **Overheating** will seriously damage the CPU and system. Always make sure the cooler (heatsink/fan) can work properly to protect the CPU from overheating. Make sure that you apply an even layer of thermal paste (or thermal tape) between the CPU and the heatsink to enhance heat dissipation.
- Confirm if your cooler is firmly installed before turning on your system.
- While **replacing the CPU**, always turn off the power supply or unplug the power supply's power cord from the grounded outlet first to ensure the safety of CPU.
- Do not touch the CPU socket content to avoid damage.
- Whenever CPU is not installed, always protect your CPU socket pins with the plastic cap covered.
- Please refer to the documentation in the CPU cooler package for more details about the CPU cooler installation.
- Read the CPU status in BIOS.

# Removing Preinstalled Liquid Cooling Module

If your system comes with a preinstalled liquid cooling module, follow the instructions below to remove it before proceeding with the CPU installation.

Follow the steps below:

1. Loosen all **screws** in a diagonal sequence.
2. Remove all **standoffs**.

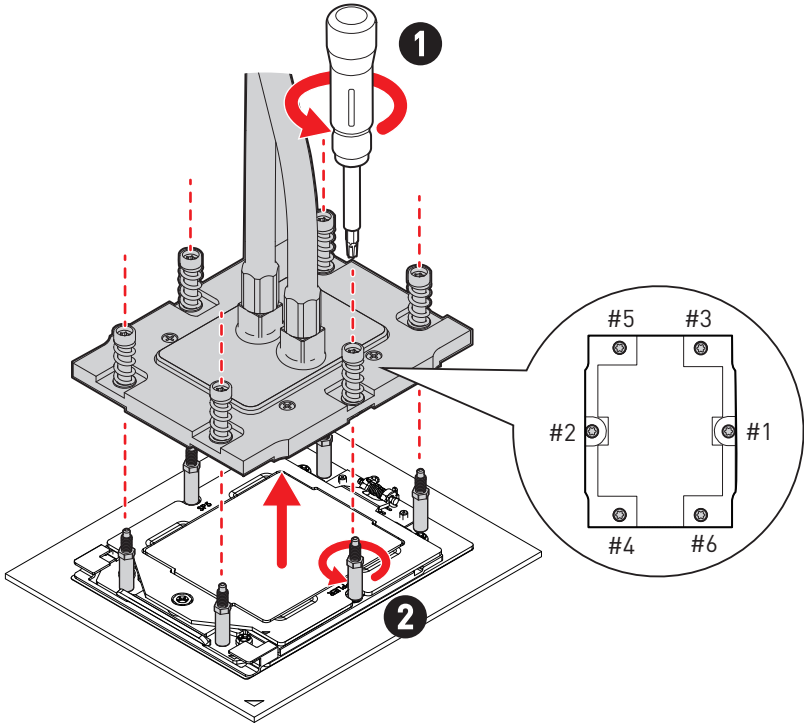

## Installing CPU

Follow the steps below to install CPU:

1. Remove the screw on the top of the retention frame.

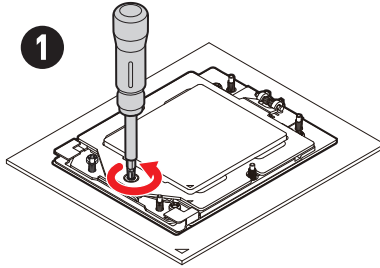

2. After removing the top screw, the **spring-loaded retention frame** will rise up. Hold it gently until it is fully open.
3. Lift the **rail frame** by gripping the lift tabs near the front edge of the rail frame.
  - As both frames are spring-loaded, keep a tight grip on them while lifting to avoid an abrupt swinging motion.

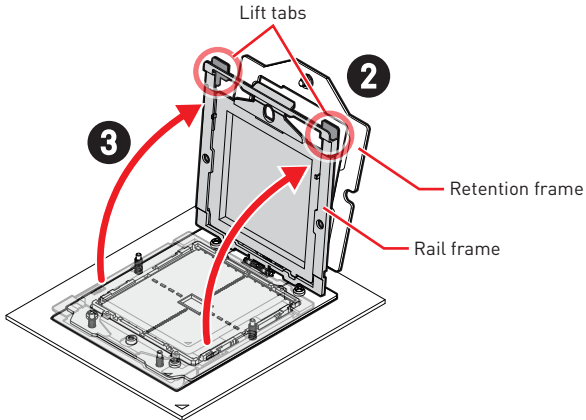

4. Pull the **external cap** upward through the rail guides on the rail frame to remove it.
  5. Grip the handle of the **carrier frame** and slide it downward with the flanges and the rail guides aligned.
- CPUs are shipped from the factory with pre-assembled carrier frames.
  - Make sure the flanges of the carrier frame are firmly loaded on the rails before closing the rail frame.

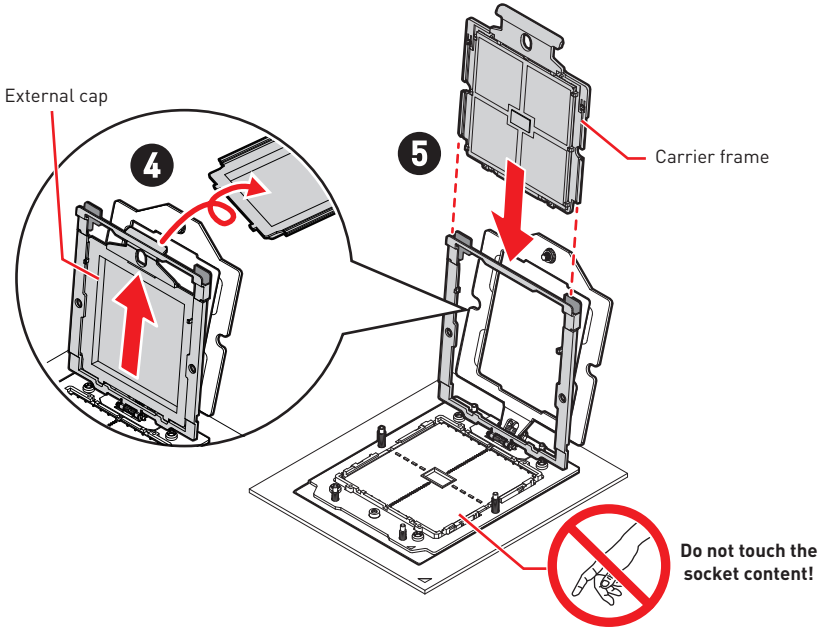

6. Grip the **lift tabs at the front edge of the rail frame** with the carrier frame loaded, then gently lower it to engage the carrier's latching mechanism to the socket housing.

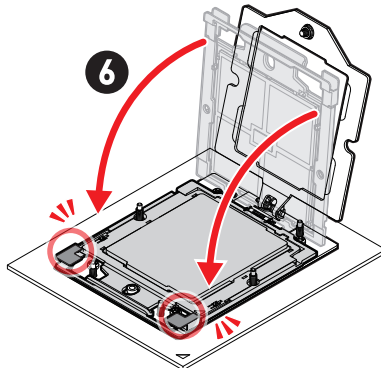

7. Push the **retention frame** downward and use a torque screwdriver to tighten the screw in the middle.

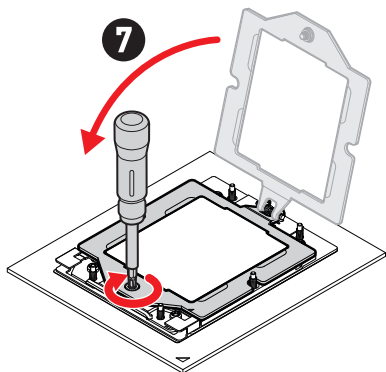

#### Torque Screwdriver Settings

**Screw Head:** Torx T20

**Torque:** 12.5-15 kgf-cm\*

\*12.5-15 kgf-cm

= 122.6-147 N-m

= 10.9-13 lbf-in

## Installing Heatsink

Follow the steps below to install heatsink:

1. For peak thermal performance, apply proper amount of **thermal paste** to the bottom center of the heatsink. (Skip this step if there is pre-applied thermal paste.)
  2. Lower the heatsink until it rests firmly in place after aligning the six screw holes on its bottom with the motherboard's studs.
  3. Tighten all screws in **diagonal sequence** with a torque screwdriver.
- To avoid damaging the fins of the heatsink, always grip the heatsink **along the axis of the fins**. Holding a heatsink along the side might damage its fins or solder.
  - To avoid distributing uneven pressure on the CPU, it is recommended to **secure the heatsink in two steps**: first, loosely attach the screws at six points and then gradually tighten them.

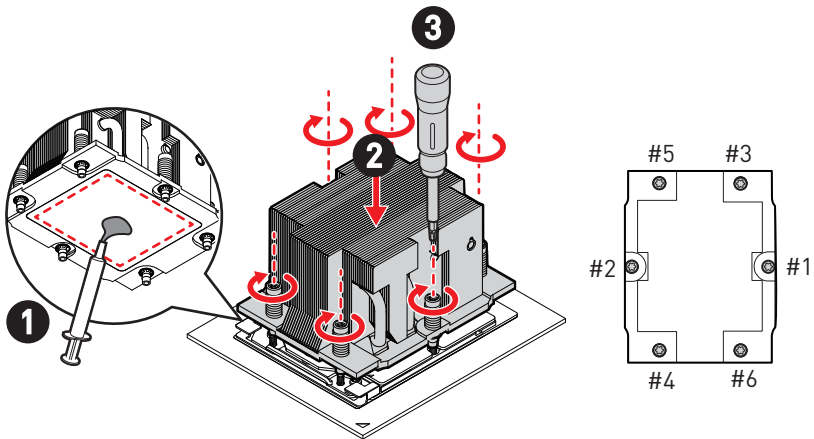

## Installing Liquid Cooling Module

Follow the steps below to install liquid cooling module:

1. Begin by removing the **bracket**. Loosen the screws on both sides of the chassis.

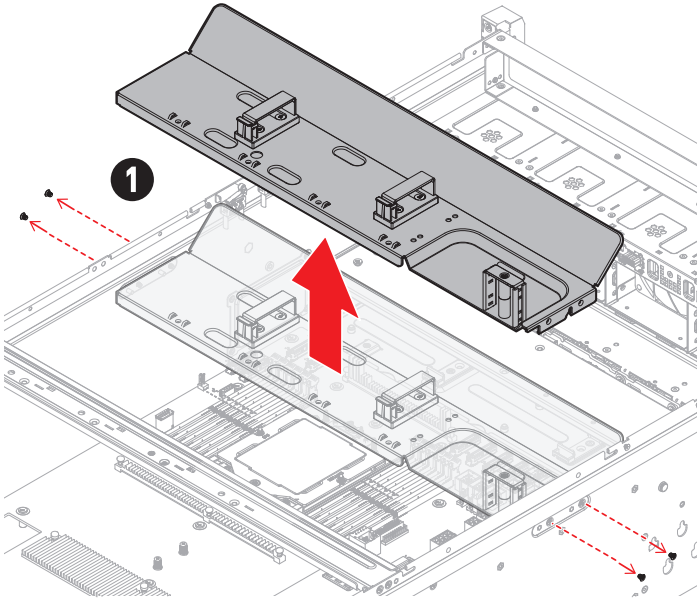

2. Remove the **M3 screws** from the **mounting bar**.

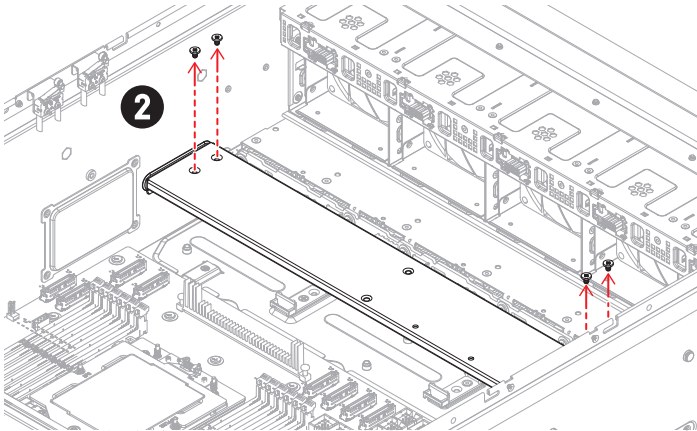



3. Ensure precise alignment of the **module's bottom panel** screw holes with the **mounting bar's** corresponding openings. Secure them with the M3 screws that were previously removed.

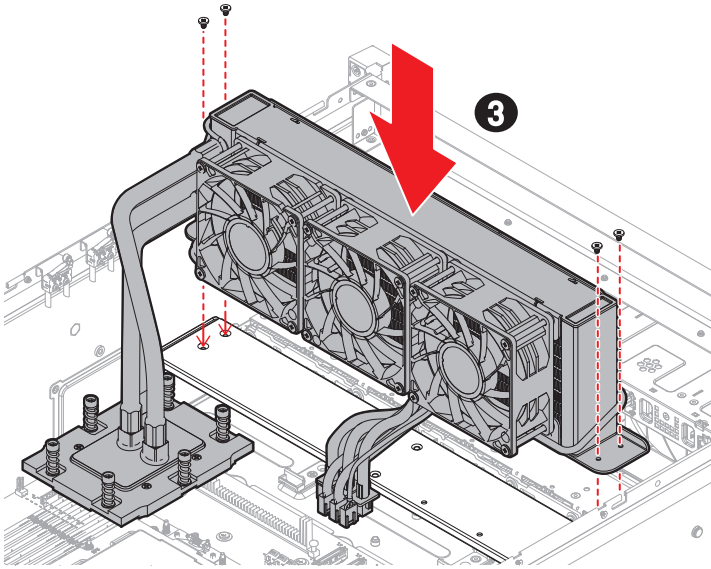

4. For peak thermal performance, apply proper amount of **thermal paste** to the bottom center of the heatsink. (Skip this step if there is pre-applied thermal paste.)
5. Align the 6 screw holes on its bottom with the system board's studs, then lower the **CPU water block** until it rests firmly in place.
6. Use a torque screwdriver to securely fasten all screws in a **diagonal sequence**.

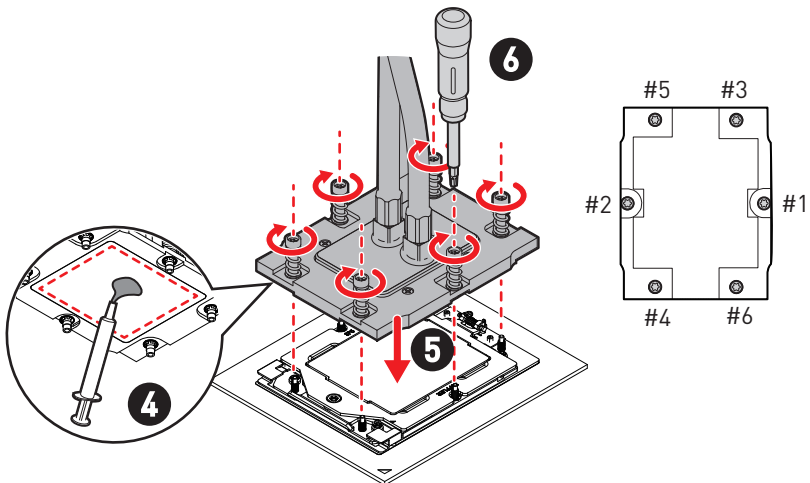

7. Connect the **fan and pump connectors** to the system board.

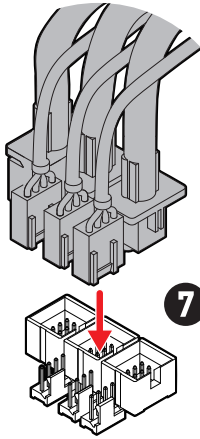

# Memory

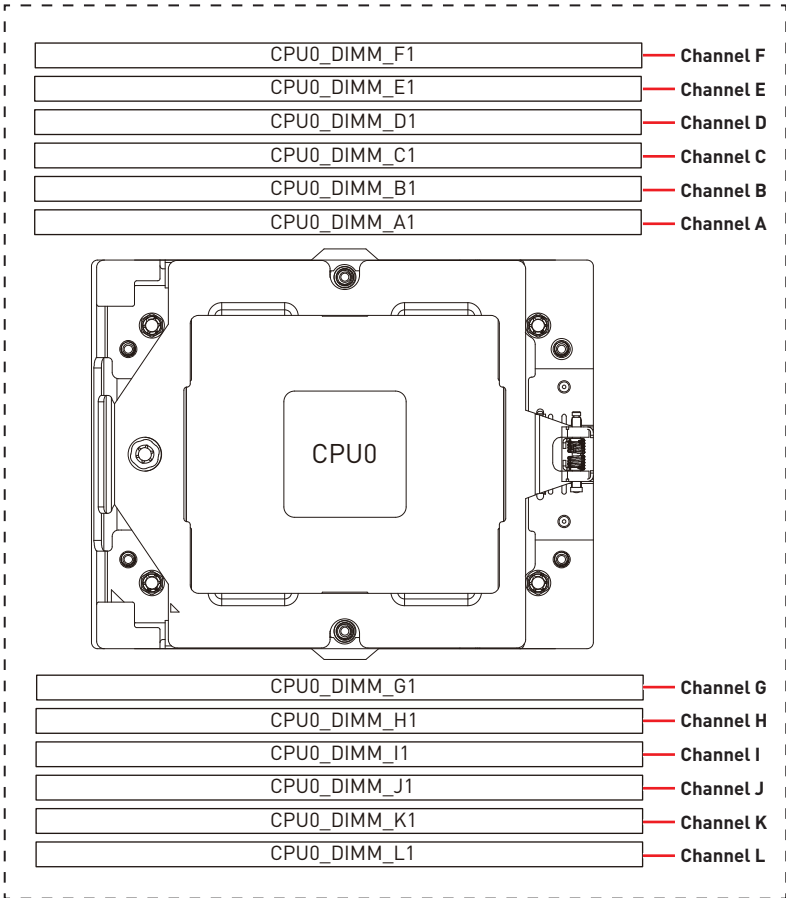

## Recommended Memory Population

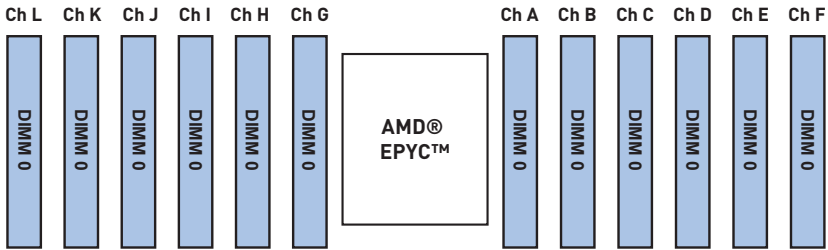

Channel Qty. of DDR5	Channel						C P U	Channel					
	L	K	J	I	H	G		A	B	C	D	E	F
12	V	V	V	V	V	V	C P U	V	V	V	V	V	V
10		V	V	V	V	V		V	V	V	V	V	
8		V		V	V	V		V	V	V		V	
6				V	V	V		V	V	V			
4				V		V		V		V			
2						V		V					
1								V					

## Key Parameters for DIMM Configuration

Parameter	Possible Values		
# of DIMMs Populated Per Channel	1DPC (1 DIMM per channel)		
DIMM Type	RDIMM, 3DS RDIMM		
DIMM Construction	RDIMM	1R (1 rank)	4800 MT/s memory speed supported
		2R (2 ranks)	
	3DS RDIMM	2S2R (4 ranks)	
		2S4R (8 ranks)	
		2S8R (16 ranks)	

### Important

- There should be at least 1 DDR5 DIMM populated.
- Paired memory installation for Max performance.
- Populate the same DIMM type in each channel, specifically: 1. Use the same DIMM size; 2. Use the same number of ranks per DIMM.
- We don't suggest other memory installation.

## Installing Memory Modules

1. Open the side clips to unlock the DIMM slot.
2. Insert the DIMM vertically into the slot, ensuring that the off-center notch at the bottom aligns with the slot.
3. Push the DIMM firmly into the slot until it clicks and the side clips automatically close.
4. Verify that the side clips have securely locked the DIMM in place.

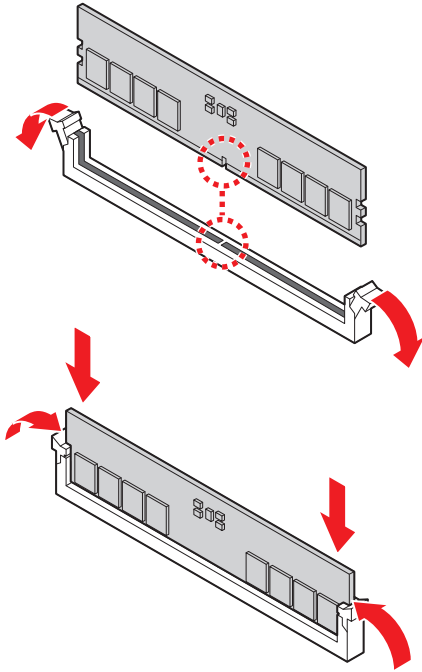

### **Important**

*You can barely see the golden finger if the memory module is properly inserted in the DIMM slot.*

# M.2 M Key

## Installing an M.2 SSD



Watch the video to learn how to Install M.2 SSD.



1. Loosen the M.2 riser screw from the motherboard.
2. Move and fasten the M.2 riser screw to the appropriate location according to your M.2 SSD size.
3. Insert your M.2 SSD into the M.2 slot at a 30-degree angle.
4. Secure the M.2 SSD in place with the supplied M.2 screw.

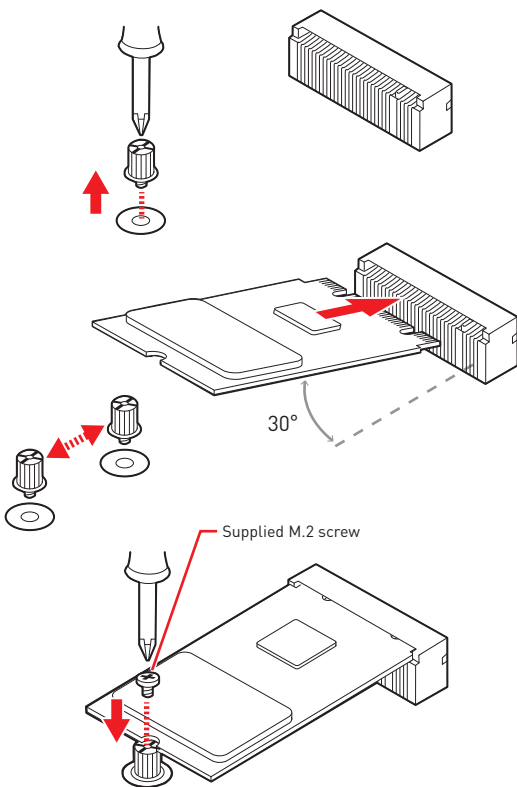

# GPGPU Card

## Installing GPGPU Card

Follow the steps below to install GPGPU card:

1. Remove the **riser bar** by loosening the screws on both sides of the chassis.

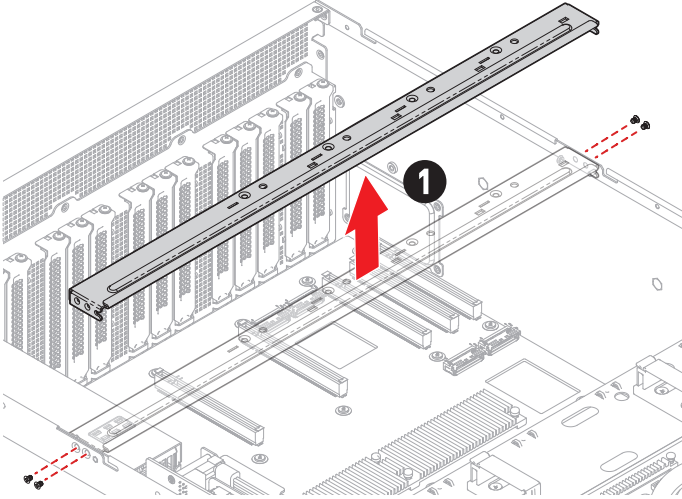

2. Attach the **GPU bracket** to the GPGPU card by tightening the screws.

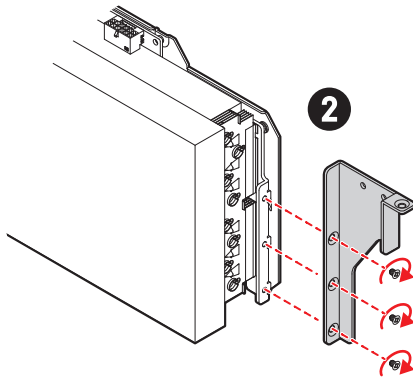

- Loosen the screws on the rear side of the chassis to remove the **PCIe bracket**.

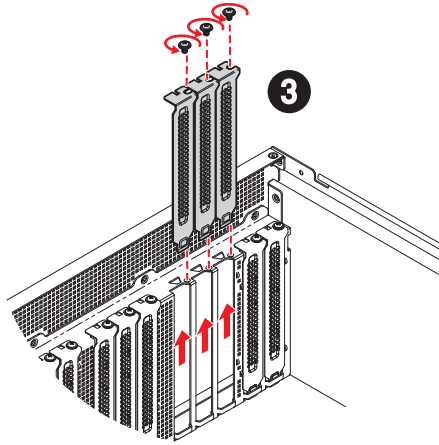

- Align the GPGPU card with the riser slot and insert it until it is fully seated.
- Tighten the screws to securely fix the **GPGPU card assembly** in place.

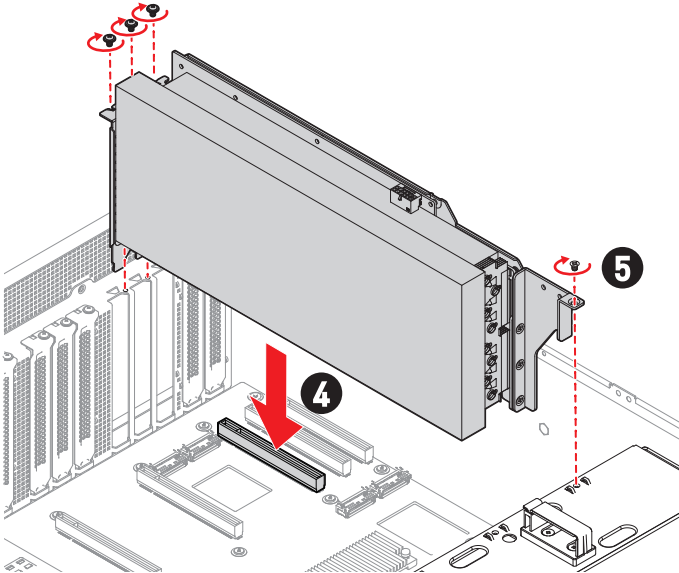

- Follow the above procedures to install other GPGPU cards.



6. Connect power cables to the **12-pin power connectors** on the GPGPU cards.

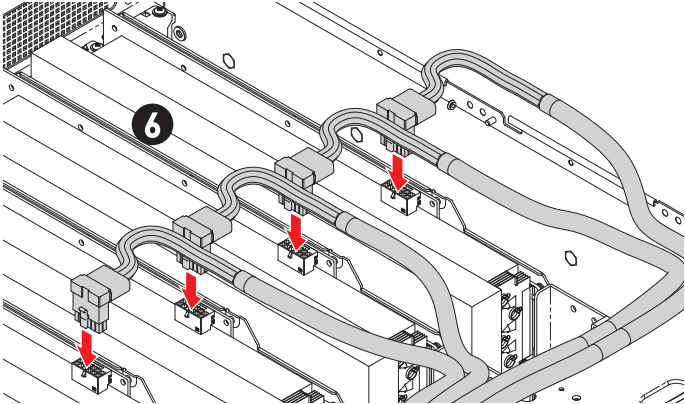

# Cable Routing

## Power Cables

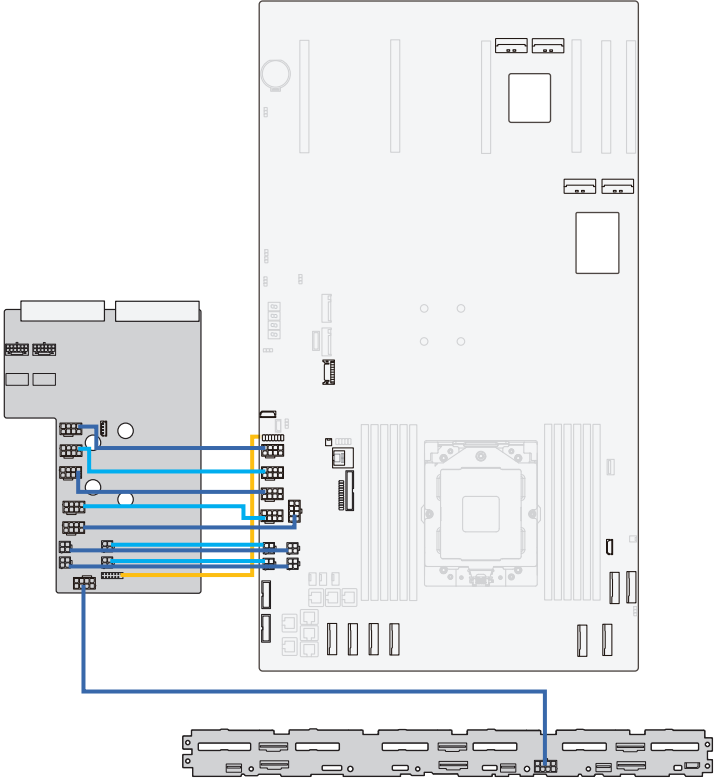

# I2C Cables

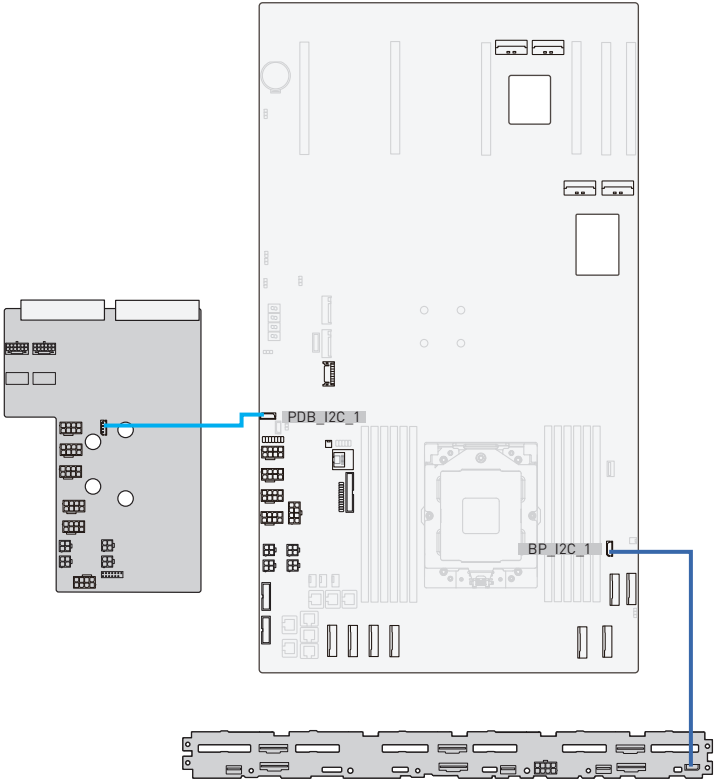

# Cables for Front & Rear I/O

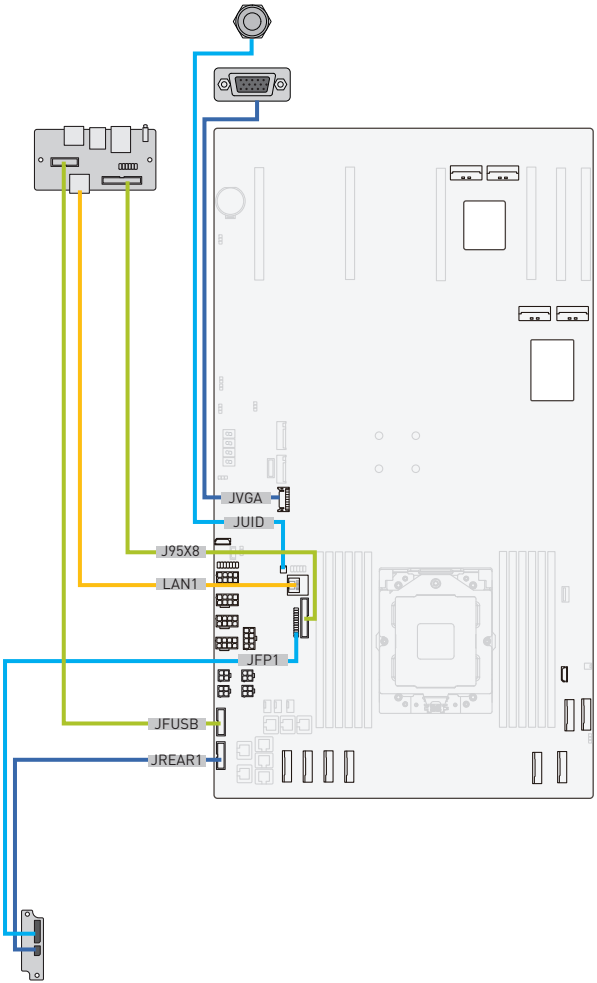

# Storage Cables

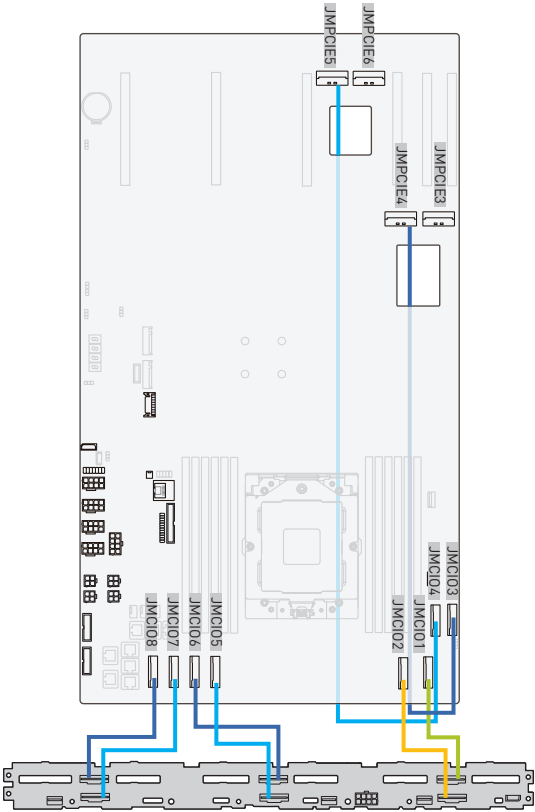

# Slide Rail



The illustrations are provided for demonstrative purposes only. The appearance of your system may differ based on the model you have purchased.

## Disassembling Slide Rail

Slide the **release tab** forward to separate the inner rail from the bracket.

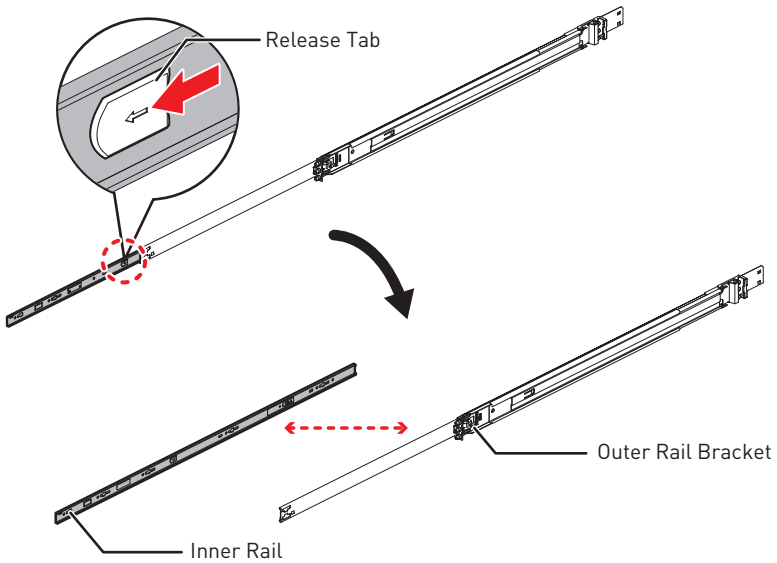

# Installing Inner Rail onto the Chassis

1. Align the standoffs on the side of the chassis with the hole on the inner rail, then **pull the inner rail backwards** till it locks into place.
  2. Tighten the screw to secure the inner rail.
- Repeat the same procedure to install the inner rail on the other side of the chassis.

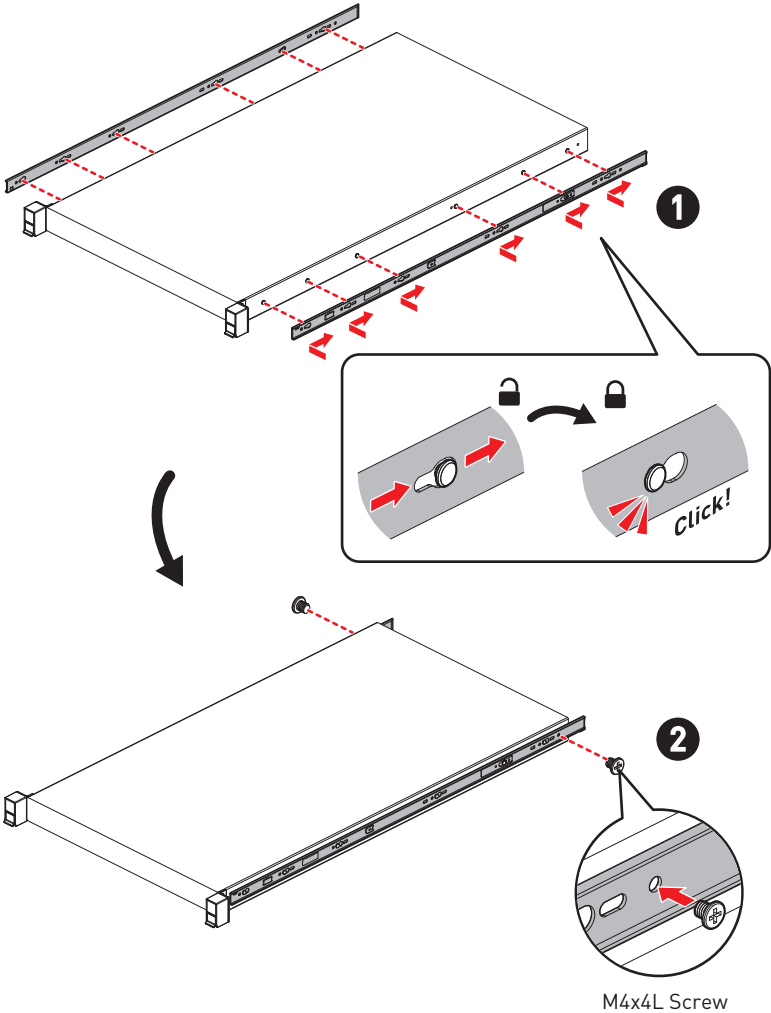

# Retracting Outer Rail Bracket

Pull the latch upward to slide the middle rail back to the outer rail bracket.

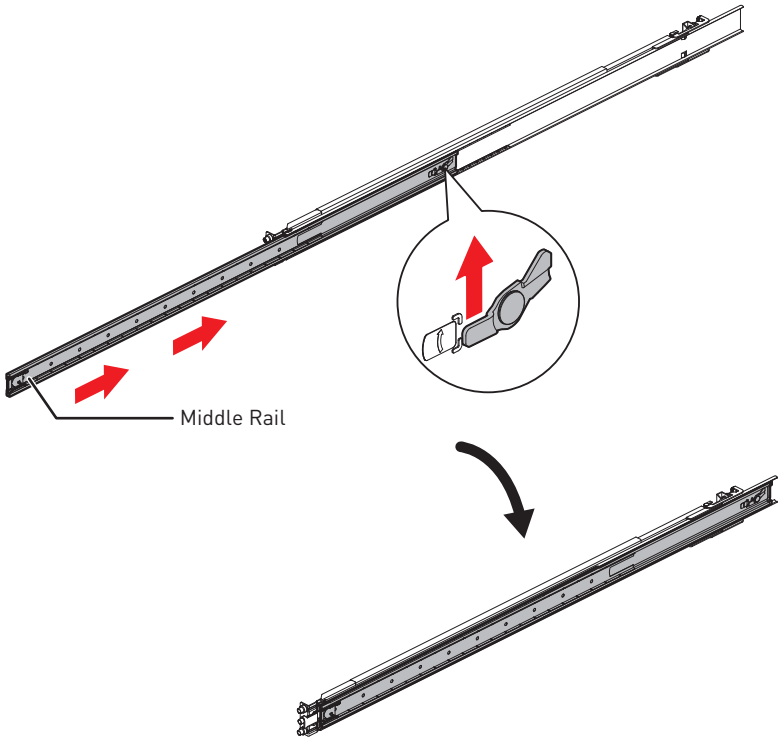



# Attaching Outer Rail Bracket to Rack Frame

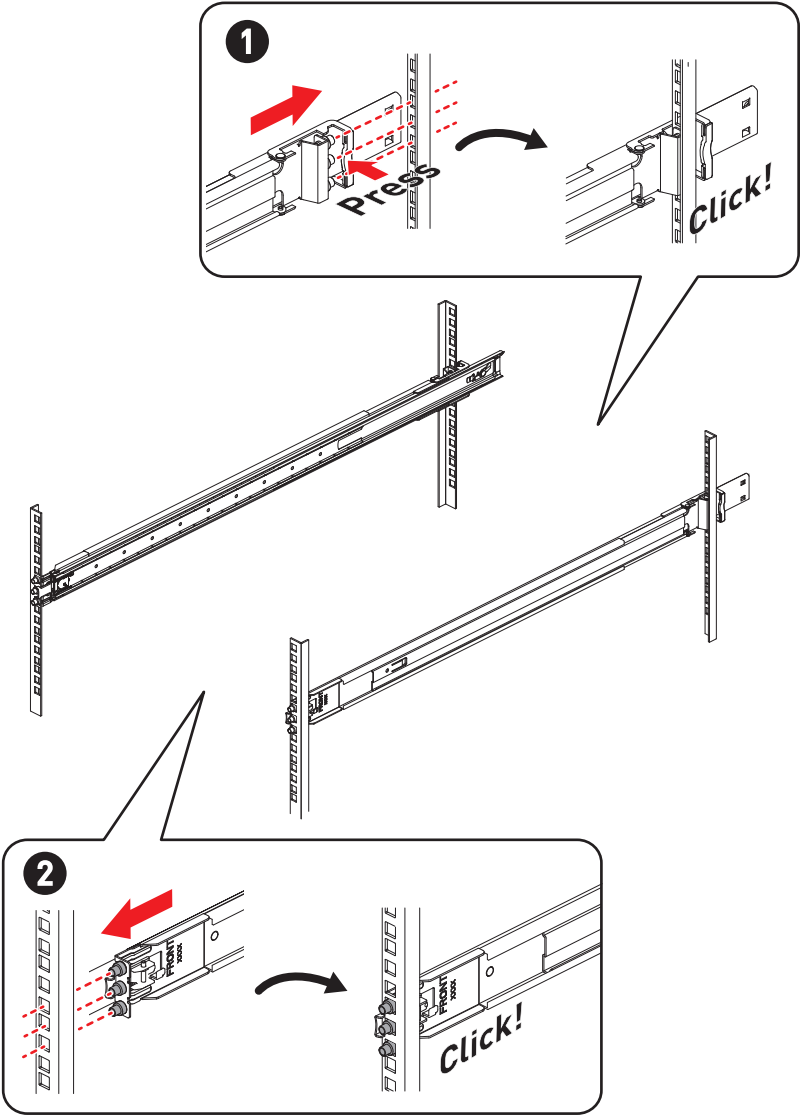

## Installing Chassis into Rack

1. Pull out the middle rails till it fully extended.
  - Ensure the **ball bearing retainers** are locked forward on each middle rail.
2. Engage the inner rails of the chassis to the middle rails, then push the chassis forward until it stops.
3. Push the chassis into the rack by sliding the **two-way release tabs** forward or backward.
4. Tighten the screws to secure the chassis.

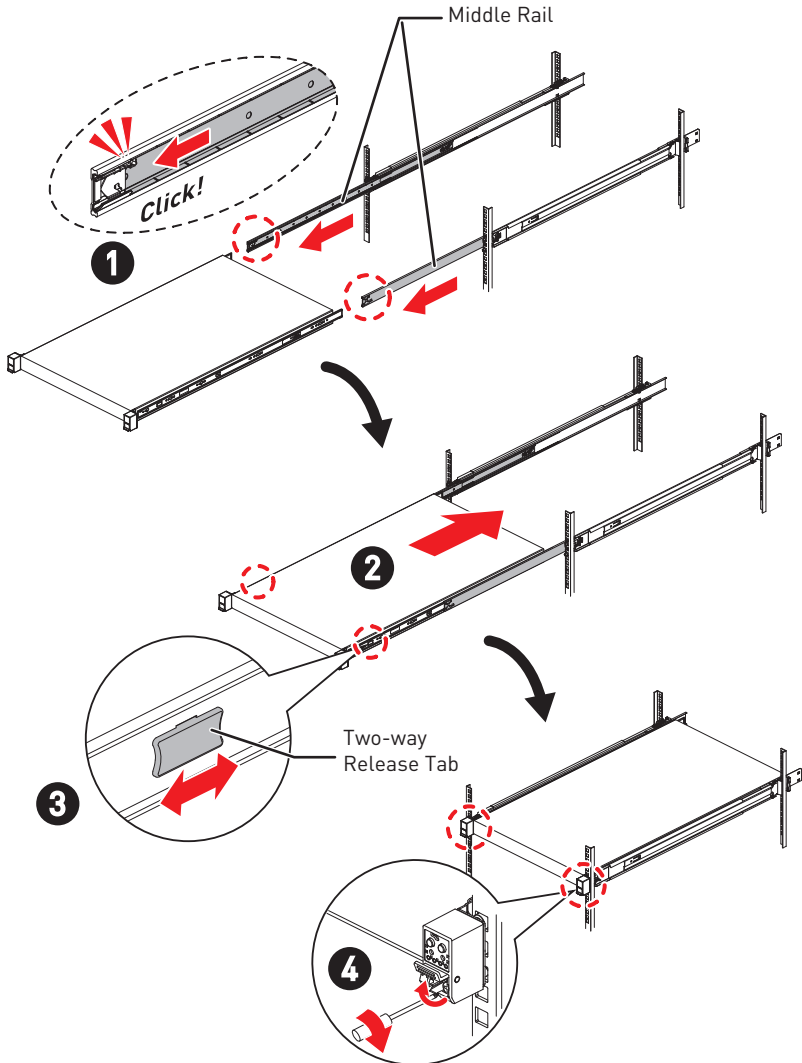

# Removing Chassis from Rack

1. Remove the screws.
2. Slide the **release tab** forward to separate the inner rail (chassis) from the bracket.

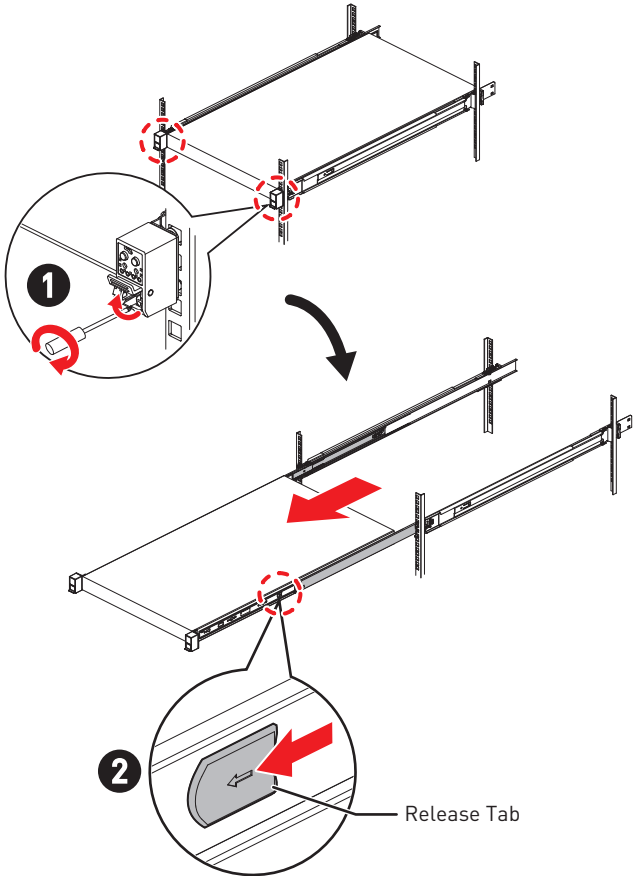

# Detaching Outer Rail Bracket from Rack Frame

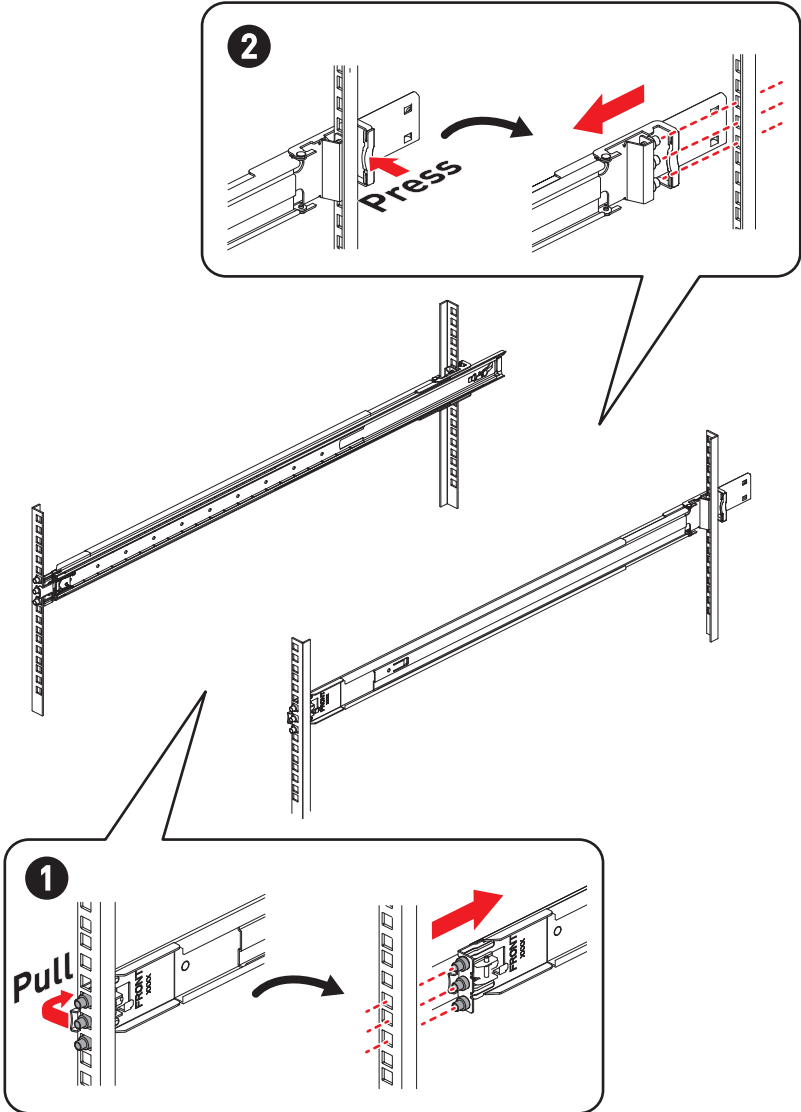

# Detaching Inner Rail from the Chassis

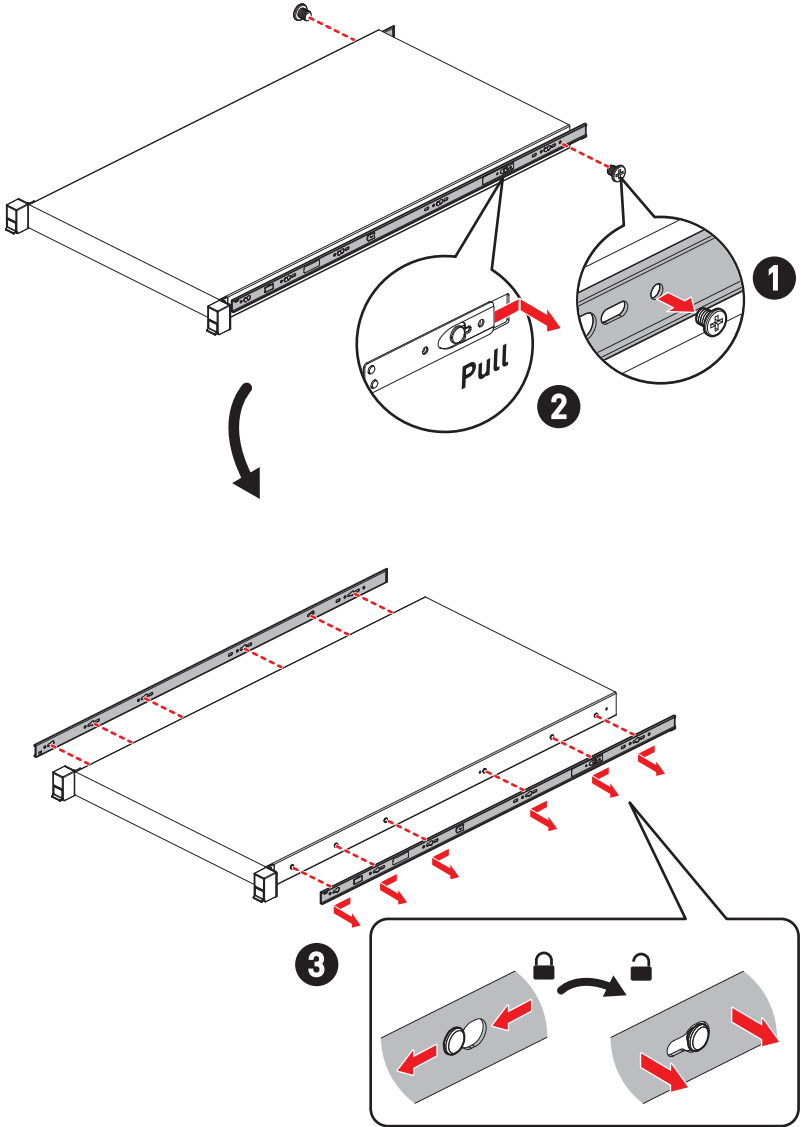



[MSI.COM](https://www.msi.com)



[EPS.MSI.COM](https://www.msi.com/eps)